

Water Management PRODUCT AND INSTALLATION MANUAL

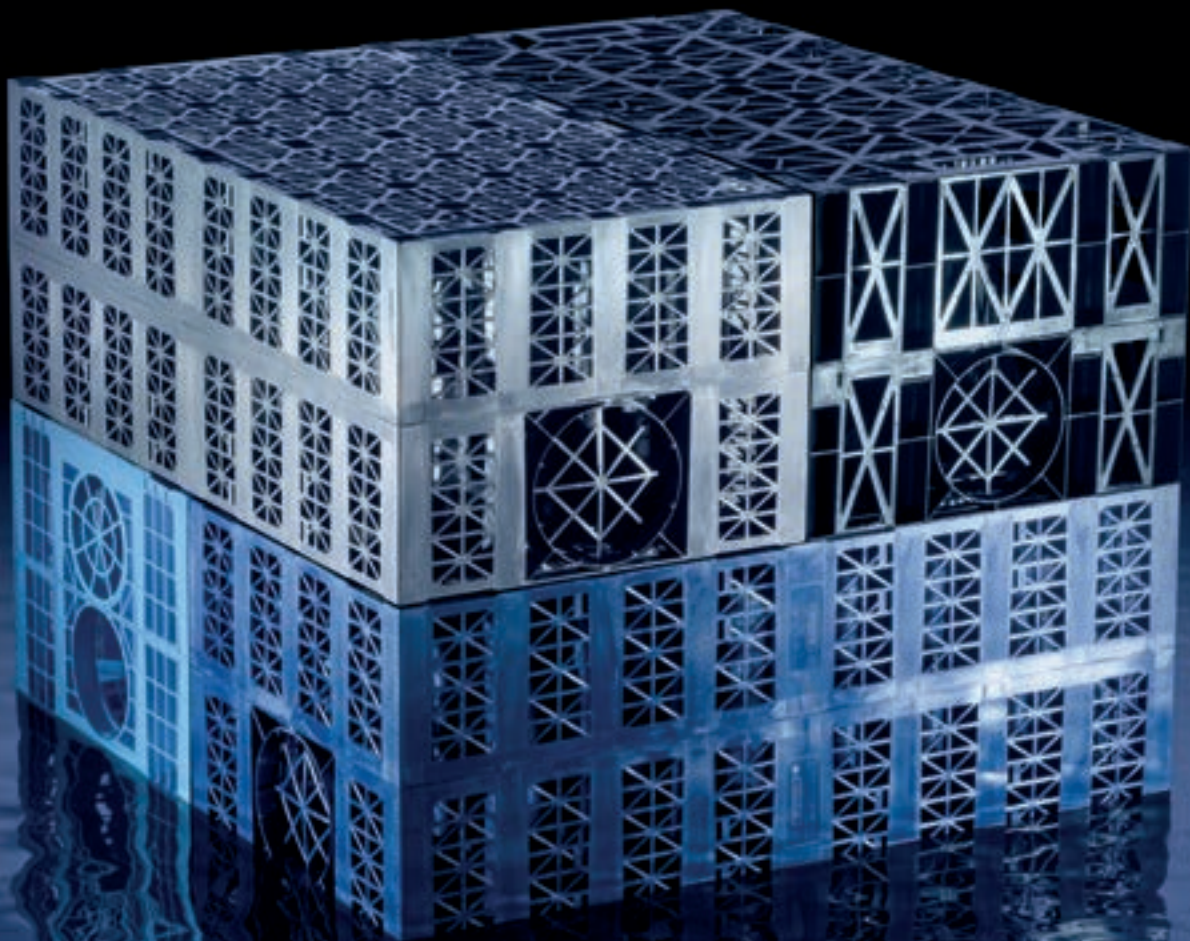

CONNECT TO BETTER

AquaCell Systems



Contents

AquaCell Systems



Introduction to SuDS	4	Installation	20	Off-Line Storage – Manifold Feed	32
Keeping you on top of legislation	5	Typical Soakaway		Off-Line Storage – Central	
Overview	6	Installation Method	20	Pipe Feed	33
Product Range Summary	8	Typical Storage Tank		Soakaway or Storage Tank	
Product Details	9	Installation Method	21	– With Silt Trap	34
AquaCell Eco	9	Silt Trap and Air Vent Termination	22	Wavin Stormwater Management	35
AquaCell Prime	10	Typical Details	23	To Achieve Optimum Stormwater	
AquaCell Core	11	Top Connection for Air Vent	23	Management	35
AquaCell Plus	12-13	Side Connection for Air Vent	23	Other Wavin Stormwater Systems	35
Design Guidance	14-18	Connections to AquaCell Units	24	The Wavin Stormwater Service	35
Installation Guidance	19	Connection Configurations	25	Product Details	
AquaCell Prime, Core and Plus:		Soakaway – Non-Traffic Loading	26	Supplementary Items	36
Construction Loads	19	Soakaway – Traffic Loading	27	Silt Traps	36
AquaCell Eco: Construction Loads	19	On-Line Storage – Box Feed	28	Ancillaries	37-38
		On-Line Storage – Manifold Feed	29	Spares	39
		On-Line Storage – Central			
		Pipe Feed	30		
		Off-Line Storage – Box Feed	31		

Introduction to SuDS

Continuing urban development, a changing climate and the consequences of increased rainfall are all increasingly prominent issues on the political and environmental agenda and all drive the need to actively manage excessive rainfall with the use of SuDS (Sustainable Drainage Systems).

SuDS techniques recommend a number of ways to control water run-off as near to where it falls, via:

- ⌚ Soft or natural SuDS
- ⌚ Hard or engineered SuDS

SuDS should also aim to mimic nature, whilst focusing on 4 key areas (as shown below):

1. Controlling run-off / flood risk
2. Improving water quality
3. Providing amenities
4. Creating an environment for biodiversity

The CIRIA SuDS Manual gives guidance on all areas of SuDS and focuses on the cost-effective planning, design, construction, operation and maintenance of SuDS.

Which SuDS Techniques are best?

- ⌚ SuDS should help maximise amenity and biodiversity, whilst also delivering key objectives to manage flood risk and water quality
- ⌚ For any given site, it is often beneficial to include a combination of 'soft' and 'hard' SuDS to ensure maximum efficiency from the Sustainable Drainage System

How can the Wavin help with SuDS projects?

Wavin is well qualified to advise on how to comply with current and emerging regulation. We can aid specifiers, developers and contractors in responding to legislative demands as they pertain to flooding, sewage, urban drainage and sustainable resources use.

In particular, the proven qualities and performance of AquaCell systems not only support the achievement of SuDS, they can also help reinforce and enhance planning applications and enable development to proceed.

CIRIA SuDS Design

Source: The SuDS Manual (CIRIA)

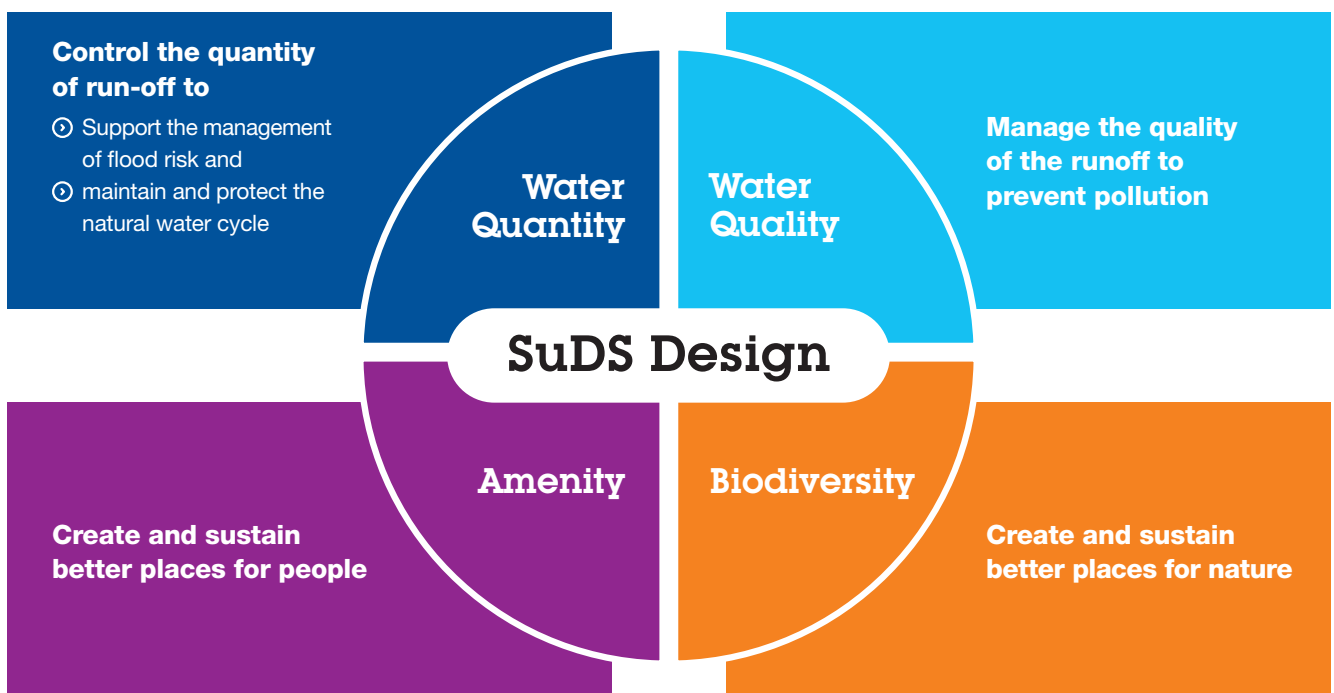

Keeping you on top of legislation

Flood and Water Management Act 2010

Climate projections suggest that extreme weather will happen more frequently in the future. The Flood and Water Management Act is designed to reduce the risk of flooding and its consequences by providing for better, more comprehensive and co-ordinated water management, embracing groundwater, surface water and coastal erosion risk.

The Act gives DEFRA responsibility for establishing national standards for sustainable drainage and empowers local authorities to manage local flood risk – adapting and maintaining sustainable drainage schemes.

Specifically with regards to stormwater, Building Regulations Approved Document H3 stipulates that adequate provision should be made for rainwater to be carried from the roof of a building to either a soakaway, water course or sewer.

The EU Water Framework Directive

Nearly half the EU population lives in ‘water-stressed’ countries, caused by high extraction from freshwater sources, and demand is growing all the time.

The EU Water Framework Directive introduces a new legislative approach designed to better manage and protect water resources, based not on national or political boundaries but on the natural formations of river basins.

Building Regulation Part H (Drainage and Waste Disposal)

Building Regulation Part H embraces the guidelines for drainage and waste disposal that must be met in the UK.

Although Part H extends to rainwater drainage and solid waste storage, waste drainage issues are to the fore. The Building Regulations are designed to ensure that all foul water (waste from urinals, portals, food preparation water etc.) is properly disposed of to maintain a decent level of sanitation, promoting both personal and environmental health.

The regulations also highlight the importance of pollution prevention, working sewage infrastructure and sewage maintenance.

Planning Policy

Statement 25: Development and Flood Risk Responding to climate change, and replacing Planning Policy Guidance Note 25, the statement PPS25 sets out policy to ensure that flood risk is taken into account at all stages of the planning process and that inappropriate development in areas at risk of flooding is avoided.

The policy directs development away from areas of highest risk and where new development is, exceptionally necessary in such areas, aims to make it safe without creating an increase in flood risk elsewhere and, where possible, reduce flood risk overall.

Statement 3: Housing PPS3 underpins the delivery of the Government’s strategic housing policy objectives. The statement replaces Planning Policy Guidance 3: Housing and earlier editions of PPS3, providing technical amendments to Annex B: Definitions to reflect the introduction of Affordable Rent.

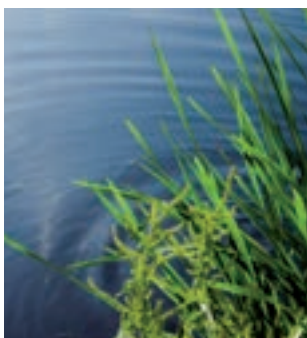

Overview AquaCell Systems

The AquaCell range of geocellular systems are a fully tried and tested, BBA approved, modular technique for managing excessive rainfall.

Applications

The AquaCell range can be used as either a temporary storage tank or as a soakaway, and is suitable for applications including:

- Ⓞ Landscaped areas
- Ⓞ Parks
- Ⓞ Domestic gardens
- Ⓞ Residential developments
- Ⓞ Car parks & roads
- Ⓞ Industrial/commercial areas



The AquaCell Range

There are four types of AquaCell unit. Each can be used as a standalone system or different unit types can be mixed and matched together in layers to value engineer the most cost effective solution.

All AquaCell units have identical dimensions (1m x 0.5m x 0.4m), but they are manufactured to perform differently. The type of unit, or combination of units required will depend on factors such as the load application, overall installation depth and site conditions.

Features & benefits

The following are applicable to all AquaCell units:

- Ⓞ Fully BBA Approved – Eco/Prime/Core/Plus are all approved under certificate No. 03/4018
- Ⓞ Modular, lightweight and versatile
- Ⓞ Easy to handle and quick to install
- Ⓞ Proven clip and peg connection system
- Ⓞ 95% void (each unit holds 190 litres of water)
- Ⓞ Can be brick-bonded for extra stability
- Ⓞ Units can be mixed and matched together for optimum performance
- Ⓞ Safer than open or above ground storage structures
- Ⓞ Full range of ancillaries
- Ⓞ Can be used as part of a SuDS scheme to help reduce flood risk

Environmental Benefits

In addition, the AquaCell range can also offer the following environmental benefits:

- Ⓞ Significantly reduced flooding risk
- Ⓞ Controlled, reduced-volume release of stormwater into existing sewer systems or watercourses
- Ⓞ Recharging of local groundwater (if infiltration/soakaway application)
- Ⓞ Aerobic purification to improve water run-off quality
- Ⓞ Sustainable, cost effective management of the water environment



AquaCell Eco



Eco is manufactured from specially reformulated, recycled material and has been designed for shallow, non-trafficked, landscape applications.

AquaCell Prime

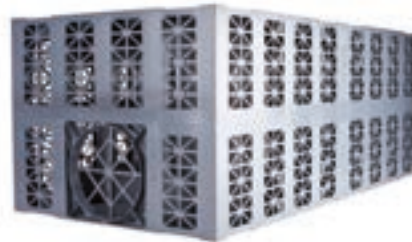

Prime is the latest addition to the AquaCell range, manufactured from specially reformulated, recycled material. It is ideal for use in both shallow and deep applications, subject to either regular traffic loading – such as car parks (for vehicles up to 12 tonnes) – or for landscaped areas.

AquaCell Core



Core has been designed for use in deep applications, subject to both regular and heavy traffic loadings, such as cars and HGV's (for vehicles up to 44 tonnes).

AquaCell Plus



Plus has been designed primarily for use in applications where inspectability is required, and is suitable for use in all applications from landscaped areas to heavily trafficked areas (for vehicles up to 44 tonnes).

Optimise tank and soakaway designs with the AquaCell Configurator Tool

The AquaCell configurator tool aids and speeds the efficient design of stormwater tank or soakaway solutions. The tool guides users through a step-by-step specification process and, based on responses, will recommend the optimum design, based on the loadings, depths and site conditions of each project. The tool generates a PDF of the design for easy download and can store the data online for future reference. To start using the tool or to learn more visit: myportal.wavin.co.uk/tools



Product Range Summary

AquaCell Systems

The Product Range Summary below lists all components available to be used in conjunction with the AquaCell range.

Abbreviations

P/E – Fittings with both ends plain or with one plain end and one special end.

S/S – Fittings with one or more ring-seal or push-fit sockets, but always one plain or special end.

D/S – Fittings with ring-seal or push-fit sockets at all ends.

▲ British Board of Agrément – BBA logo identifies non-Kitemarked fittings covered by British Board of Agrément Certificate

Table 1: The Product Range Summary

Product Description	Inlet Size (mm)	110	150	160	225	Page
Modular Units	AquaCell Eco – 1m x 0.5 x 0.4m ▲			●		9
	AquaCell Prime – 1m x 0.5 x 0.4m ▲			●		10
	AquaCell Core – 1m x 0.5 x 0.4m ▲			●		11
	AquaCell Plus – 1m x 0.5 x 0.4m ▲			●		12
Silt Traps	Silt Trap – Domestic	●				36
	Extension Piece – for Domestic Silt Trap					36
	Silt Bucket - for Domestic Silt Trap					36
	Silt Trap - Trafficked			●		36
Ancillaries	S/S Adaptor – UltraRib		●			37
	S/S Level Invert Reducer – 160mm UltraRib to 110mm spigot		●			37
	S/S Adaptor – TwinWall 6TW socket x 160mm OsmaDrain spigot		●			37
	S/S Level Invert Reducer – 160mm OsmaDrain to 110mm spigot			●		38
	P/E Adaptor – Solid Wall 160mm OsmaDrain spigot			●		38
	Flange Adaptor – for 150mm UltraRib connections		●			38
	Flange Adaptor – for 225mm UltraRib connections				●	38
Spares	AquaCell Clip – for use with all types of AquaCell units					39
	AquaCell Shear Connector – for use with all types of AquaCell units					39
	AquaCell Plus End Cap			●		39

Product Details AquaCell Eco

Application

AquaCell Eco is manufactured from specially reformulated, recycled material and has been specifically designed for shallow, non-trafficked, landscaped applications. AquaCell Eco is **NOT** suitable for locations subject to high water tables.

AquaCell Eco is typically suitable for installations to a maximum depth of 1.5 metres, to the base of the units from ground level, with a minimum cover depth of 0.3 metres, (Wavin's recommendation, is to allow a cover depth of 0.5 metres).

Any installation using AquaCell Eco must **NOT** be subjected to additional loading at any time. Trafficking by construction plant on site, including mechanical equipment, must be avoided.

If trafficking of the buried tank by construction plant or, other vehicles is unavoidable, the installation should be constructed using AquaCell Core units (see page 11).

The width of an AquaCell Eco installation should not exceed 12 metres to allow for mechanical backfilling without loading. There is no limit to the length of the installation.

Features and benefits

- ⦿ Manufactured from specially reformulated, recycled material
- ⦿ Suitable for both soakaway and attenuation applications
- ⦿ Proven vertical loading capacity of: 17.5 tonnes/m²
- ⦿ Proven lateral loading capacity of: 4.0 tonnes/m²
- ⦿ Integral "hand holds" for ease of carrying/handling
- ⦿ Black in colour, for ease of identification
- ⦿ BBA approved – Certificate No 03/4018

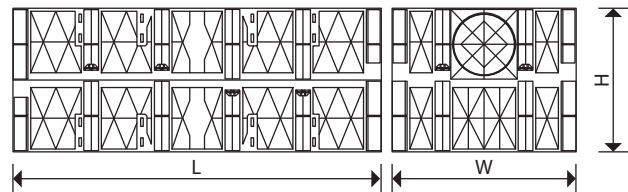

Material: Reformulated polypropylene

Nominal Size (mm)	Part Number	Dimensions (mm)		
		W	H	L
160	6LB025	500	400	1000

APPROVED

17.5 tonnes/m²

4 tonnes/m²

LOADING

MAX INVERT DEPTH 1.5m
NON-LOADED

MIX AND MATCH

Maximum installation depths (to base units) and minimum cover depths ⁽¹⁾

Typical soil type	Typical angle of shearing	Maximum depth of installation (m)	Minimum cover depth (m)
Stiff over-consolidated clay (e.g. London clay)	24°	0.95	0.30
Normally consolidated silty, sandy clay (e.g. alluvium, made ground)	26°	1.05	0.30
Loose sand and gravel	29°	1.2	0.30
Medium dense sand and gravel	33°	1.5	0.30
Dense sand and gravel	38°	1.9	0.30

(1) These values relate to installations where the groundwater is a minimum of one metre below the base of the excavation. AquaCell Eco units should not be used where groundwater is present.

Source: BBA

Product Details

AquaCell Prime

Application

AquaCell Prime is manufactured from specially reformulated, recycled material. It is ideal for use in both shallow and deep applications, subject to either regular traffic loading – such as car parks (for vehicles up to 12 tonnes) or for landscaped areas.

Typically AquaCell Prime is suitable for installations to a maximum depth of 3.70m in landscaped areas (3.45m trafficked) to the base of the units from ground level, in best soil conditions.

Features and benefits

- ⦿ Manufactured from specially reformulated, recycled material
- ⦿ Suitable for both soakaway and attenuation applications
- ⦿ Suitable for regular traffic loading, e.g. car parks
- ⦿ Proven vertical loading capacity of: 45.6 tonnes/m²
- ⦿ Proven lateral loading capacity of: 7 tonnes/m²
- ⦿ Grey in colour, for ease of identification
- ⦿ BBA approved – Certificate No 03/4018
- ⦿ Ideal for major attenuation and infiltration schemes

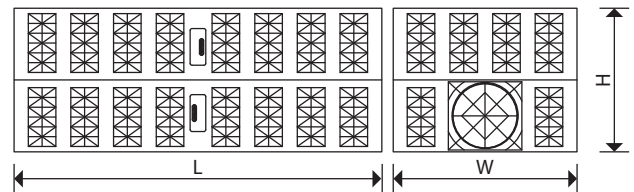
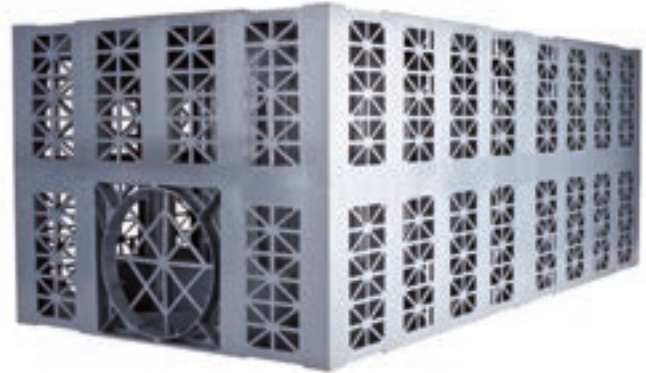

Material: Reformulated polypropylene

Nominal Size (mm)	Part Number	Dimensions (mm)		
		W	H	L
160	6LB075	500	400	1000



Maximum installation depths (to base units)

Typical soil type	Typical angle of shearing resistance (1) (2) (φ)	Maximum depth of installation – to base of units (m)			
		With groundwater at 1m below ground level and units wrapped in geomembrane		Without groundwater below base of units (normal case)	
		Trafficked areas (cars only) (3)	Non-trafficked areas	Trafficked areas (cars only) (3)	Non-trafficked areas
Stiff over-consolidated clay (e.g. London clay)	24°	1.60	1.78	1.73	1.98
Normally consolidated silty, sandy clay (e.g. alluvium, made ground)	26°	1.75	1.90	2.01	2.27
Loose sand and gravel	30°	1.95	2.08	2.58	2.86
Medium dense sand and gravel	34°	2.04	2.16	2.98	3.24
Dense sand and gravel	38°	2.14	2.24	3.45	3.70

- (1) Loosening of dense sand or softening of clay by water can occur during installation. Designer to factor in when selecting φ value.
- (2) The design is very sensitive to small changes in the assumed value of φ, therefore, it should be confirmed by a chartered geotechnical engineer. In clay soils, it may be possible to utilise cohesion in some cases.
- (3) Applicable for car parks or other areas trafficked only by cars or occasional refuse collection trucks or similar vehicles (typically one per week). Assumptions made are: ⦿ ground surface is horizontal ⦿ shear planes or other weaknesses are not present within the structure of the soil

Source: BBA

Product Details AquaCell Core

Application

AquaCell Core has been designed for use in deep applications, subject to regular and heavy traffic loadings, e.g. cars and HGV's (for vehicles up to 44 tonnes). AquaCell Core can also be used for deep soakaways and landscaped applications.

Typically for use down to depths of 4.25m in landscaped areas (4.1m trafficked by cars and 4m trafficked by HGV's) to the base of the units from ground level, in best soil conditions.

Trafficking by heavy construction plant on site, including mechanical equipment, must be avoided until the minimum cover depth of 0.9 metres is in place.



Features and benefits

- ⦿ Suitable for regular and heavy traffic loadings
- ⦿ Proven vertical loading capacity of: 56 tonnes/m²
- ⦿ Proven lateral loading capacity of: 7.7 tonnes/m²
- ⦿ Dark blue in colour, for ease of identification
- ⦿ BBA approved – Certificate No 03/4018
- ⦿ Ideal for all types of shallow and deep projects including major attenuation and infiltration schemes

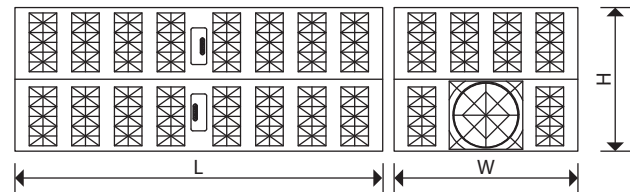

Material: Polypropylene

Nominal Size (mm)	Part Number	Dimensions (mm)		
		W	H	L
160	6LB100	500	400	1000



Maximum installation depths (to base units)

Typical soil type	Typical angle of shearing resistance (1) (2) (φ)	Maximum depth of installation – to base of units (m)			
		With groundwater at 1m below ground level and units wrapped in geomembrane		Without groundwater below base of units (normal case)	
		Trafficked areas (cars only) (3)	Non-trafficked areas	Trafficked areas (cars only) (3)	Non-trafficked areas
Stiff over-consolidated clay (e.g. London clay)	24°	1.65	1.75	2.35	2.50
Normally consolidated silty, sandy clay (e.g. alluvium, made ground)	26°	1.70	1.80	2.50	2.65
Loose sand and gravel	29°	1.80	1.90	2.85	2.95
Medium dense sand and gravel	33°	1.90	2.00	3.30	3.45
Dense sand and gravel	38°	2.05	2.15	4.10	4.25

(1) Loosening of dense sand or softening of clay by water can occur during installation. Designer to factor in when selecting φ value.

(2) The design is very sensitive to small changes in the assumed value of φ, therefore, it should be confirmed by a chartered geotechnical engineer. In clay soils, it may be possible to utilise cohesion in some cases.

(3) Applicable for car parks or other areas trafficked only by cars or occasional refuse collection trucks or similar vehicles (typically one per week). Assumptions made are: ⦿ ground surface is horizontal ⦿ shear planes or other weaknesses are not present within the structure of the soil

Source: BBA

Product Details

AquaCell Plus

Application

AquaCell Plus has been designed primarily for use in applications where inspectability is required, and is suitable for use in all applications from landscaped areas to heavily trafficked areas (for vehicles up to 44 tonnes). The units can be used in combination with AquaCell Prime and Core (and Eco if there is at least one layer of Prime or Core in between the Plus and Eco layer).

Extra lateral loading capacity allows installation at greater depths. Integral inspection channels in each unit combine to create viewing channels for the full length of the installed structure.

Typically for use down to depths of 5.08m in landscaped areas (4.78m trafficked by cars and 4.48m trafficked by HGV's) to the base of the units from ground level, in best soil conditions. Trafficking by heavy construction plant on site, including mechanical equipment, must be avoided until the minimum cover depth of 0.9 metres is in place.

Features and benefits

- ⦿ Suitable for extra deep installations
- ⦿ Inspectable (supplied with end cap for use when an inspection channel is not required)
- ⦿ Proven vertical loading capacity of: 65 tonnes/m²
- ⦿ Proven lateral loading capacity of: 8.5 tonnes/m²
- ⦿ Light blue in colour, for ease of identification
- ⦿ BBA approved – Certificate No 03/4018

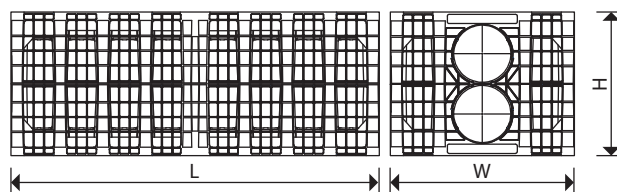
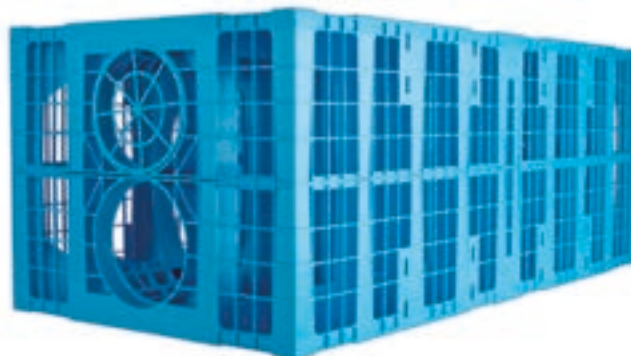

Material: Polypropylene

Nominal Size (mm)	Part Number	Dimensions (mm)		
		W	H	L
160	6LB200	500	400	1000

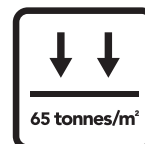

Maximum installation depths (to base units)

Typical angle of shearing resistance ⁽¹⁾ ⁽²⁾ (ϕ)	Maximum depth of installation – to base of units (m)		
	Non-trafficked areas	Cars ⁽³⁾	HGV
24°	2.96	2.65	2.35
26°	3.18	2.88	2.57
28°	3.42	3.12	2.82
30°	3.69	3.39	3.08
32°	3.98	3.68	3.38
34°	4.31	4.01	3.71
36°	4.68	4.38	4.07
38°	5.08	4.78	4.48

(1) Loosening of dense sand or softening of clay by water can occur during installation. Designer to factor in when selecting ϕ value.

(2) The design is very sensitive to small changes in the assumed value of ϕ, therefore, it should be confirmed by a chartered geotechnical engineer. In clay soils, it may be possible to utilise cohesion in some cases.

(3) Applicable for car parks or other areas trafficked only by cars or occasional refuse collection trucks or similar vehicles (typically one per week).

Assumptions made are: ⦿ ground surface is horizontal ⦿ shear planes or other weaknesses are not present within the structure of the soil

Source: BBA

Product Details

AquaCell Plus

AquaCell Plus: for inspectability

By aligning AquaCell Plus units end-to-end, full length viewing channels can be created – allowing for CCTV inspection if required. These are created in the bottom layer of an AquaCell tank installation.

The units can be used in combination with AquaCell Prime and Core (and with Eco if there is at least one layer of AquaCell Prime or Core in between the Plus and Eco layer).

NOTE: For any AquaCell Plus units on the perimeter of a structure that are NOT required for inspection access, the open ends of the integral inspection tunnels should be fitted with the end caps provided.

Inspection chambers

An inspection chamber should precede the inlet pipework for the AquaCell structure.

A silt trap or hydro-dynamic separator prior to the inspection chamber is also recommended.

For on-line installations the following Chambers are recommended:

- Down to 3m Wavin Non-Entry Inspection Chambers
- Down to 5m Wavin Range 600 Inspection Chambers, or a traditional manhole*

**where inlet pipework is replaced by AquaCell units acting as flow conduit.*

For off-line installations:

- Manhole with in-built flow control

Recommendation: If installing any Wavin Non-Entry Inspection Chamber, deeper than 1.2 metres, ensure that the cover and frame includes a 350mm restrictor to prevent man entry.

Inspection and maintenance

CCTV inspection at every inspection point is recommended:

- after every major storm
- at regular intervals according to the specific maintenance plan for the site

Silt traps prior to inlet pipework should be routinely inspected and cleaned out to minimise debris reaching the tank. It is important to prevent construction silt from entering the AquaCell structure.

Inspectability Scenarios

AquaCell Plus viewing channel



Trafficked tank installation with inspection chambers

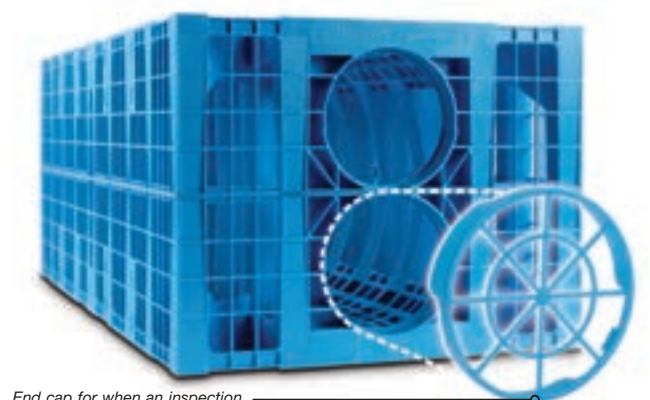
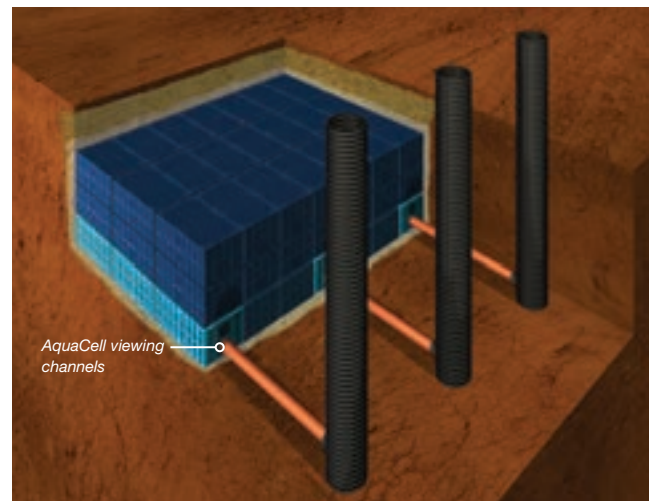

AquaCell Plus 6LB200

Design Guidance

AquaCell Units

Infiltration or attenuation?

The AquaCell range can be used either as:

- ① A soakaway whereby the units will be installed in suitable pervious soils so the units can be wrapped in a geotextile to allow infiltration of the stormwater into the surrounding ground, or
- ① As an attenuation tank in impervious ground (e.g. clay) where infiltration is not possible, here the units are encapsulated in a geomembrane (which is in turn wrapped in a protective geotextile layer) so that the structure can hold the stormwater temporarily until local drainage flows can accept it for normal disposal at a permissible outflow rate.

Large scale AquaCell Core storage tank



Domestic AquaCell Core soakaway

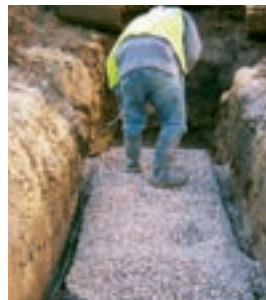

Site assessment

Ground conditions may be established as part of a geotechnical assessment. This may include tests for infiltration and ground water level.

If there is no confirmation that such assessments have been conducted, or resulting conclusions are unavailable, a trial pit will be required in accordance with BRE 365.

For further information and guidance, please contact the Wavin Technical Design Team.

Infiltration (soakaways)

According to the principals of SuDS, wherever possible stormwater should be drained back into the ground via a soakaway as the first priority. A site must meet BOTH of the following criteria for infiltration to be possible:

- ① The underlying soil surrounding the proposed installation is sufficiently permeable
- ① The seasonally high water table is a minimum of 1 metre below the base of the proposed installation

If either of these criteria is not met, or cannot be confirmed for any reason, a soakaway system may not be suitable for the application, in which case a storage tank must be used.

Attenuation (Storage tanks)

A storage tank may be designed to be online or offline (see pages 28-33 for typical details). However, if the site is subject to groundwater or a high water table, it is important to ensure that the tank is not vulnerable to flotation. Sufficient weight from soil, or other covering placed over the AquaCell units, must be sufficient to counter any buoyancy uplift force from the rising groundwater level.

Important design considerations for geocellular structures

Rising rainfall levels and increased focus on SuDS compliance, have led to a sharp increase in the use of modular units to create underground structures for infiltration or the temporary storage of stormwater.

However, not all currently available systems have the proven performance characteristics necessary to meet the wide range of complex underground geocellular applications.

The Wavin range of AquaCell units provide assured performance, since all strength and hydraulic capabilities have been verified by independent testing and all units are fully BBA approved.

To guarantee the structural integrity of an engineered drainage system, any underground structure must be strong enough to support the loads to which it will be subjected without any unacceptable deflection.

The correct choice of geocellular unit must have appropriate proven top (vertical) and side (lateral) load bearing capacity and deflection characteristics to suit site conditions.

The five key site considerations to be noted when designing a geocellular structure are:

1. Depth of cover (See page 16)
2. Soil type
3. Surface finishing
4. Presence of groundwater
5. Type of traffic/loading

The combination of these 5 factors effectively means that the

Non-trafficked

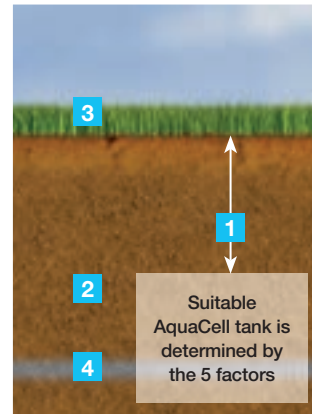

Trafficked

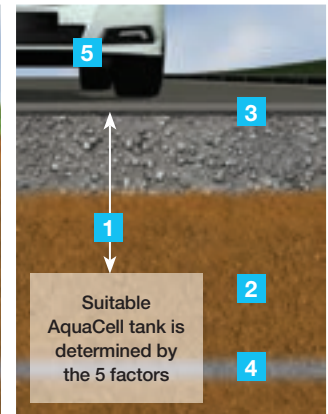

required characteristics of a geocellular structure to be installed under a trafficked location (for example) will be very different from that under a landscaped/low-loaded location.

Two typical examples are given below.

EXAMPLE A: Landscaped/non-trafficked location and 0.3m cover depth. Typically requires minimum vertical strength of 17.5 tonnes/m²

EXAMPLE B: Car park with occasional light delivery traffic and between 0.71 – 0.75m cover depth. Typically requires minimum vertical strength of 40 tonnes/m²

Design Guidance AquaCell Units

Hydraulic Design

All AquaCell units have identical dimensions: 1m x 0.4m x 0.5m, have a nominal void ratio of 95% and each holds 190 litres of water. Hydraulic calculations are accordingly the same for AquaCell Eco, Prime, Core and Plus.

Structural design however, requires careful consideration of loading factors specific to each location – see CIRIA C680 and CIRIA C737 for further guidance.

Structural Design – Installation & cover depths

Each AquaCell unit has been designed to have specific loading capacities (see pages 9-12) that define the maximum depth parameters for which they are suitable.

Minimum depth of cover varies according to whether or not the installation will be subject to trafficking by cars/HGVs.

However, in some situations, installations may have to be located with greater cover depths. Reasons may include:

- ④ Deep-running drainage network
- ④ Other buried services running above tank location
- ④ Installation into banked/ sloping ground
- ④ Upper layer of clay preventing infiltration.

The table shows a summary of typical cover depths and installation depths as a guide.

Typical minimum cover depths and maximum installation depths

Location type	Minimum cover depths			
	AquaCell Eco	AquaCell Prime	AquaCell Core	AquaCell Plus
Landscaped/non-trafficked areas	0.3m ^b	0.3m ^b	0.3m ^b	0.3m ^b
Car parks, vehicle up to 12000 kg ^a gross mass	n/a	0.71m	0.75m	0.75m
HA/HGV loading ^a	n/a	n/a	1.2m	1.1m
Maximum installation depths				
Maximum depth to base of unit (Landscaped)	1.5m	3.7m	4.25m ^c	5.08m
Maximum depth to base of unit (Trafficked)	n/a	3.45m	4.1m	4.78m

- (a) For specific advice on cover depths for heavier loadings/HGV applications, contact Wavin Technical Design on 0844 856 5165.
- (b) 0.3 is minimum depth for AquaCell Eco, although 0.5m cover is recommended to prevent accidental damage. If construction plant is to be used on site, extra protection may be needed.
- (c) Allowable maximum depth to base of bottom layer of units is dependent on soil type, angle of shearing resistance, loadings, and groundwater level. The above depths are based on 38° angle of shearing resistance and no groundwater.

The height of any tank should not exceed 2m (5 units). If you require a tank that exceeds this, please contact Wavin Technical Design for guidance:

T: 0844 856 5165 E: technical.design@wavin.co.uk

Minimum cover and maximum installation depths to base of units from ground level, in best soil conditions

This chart shows how deep each unit can be used for different applications in best soil conditions.

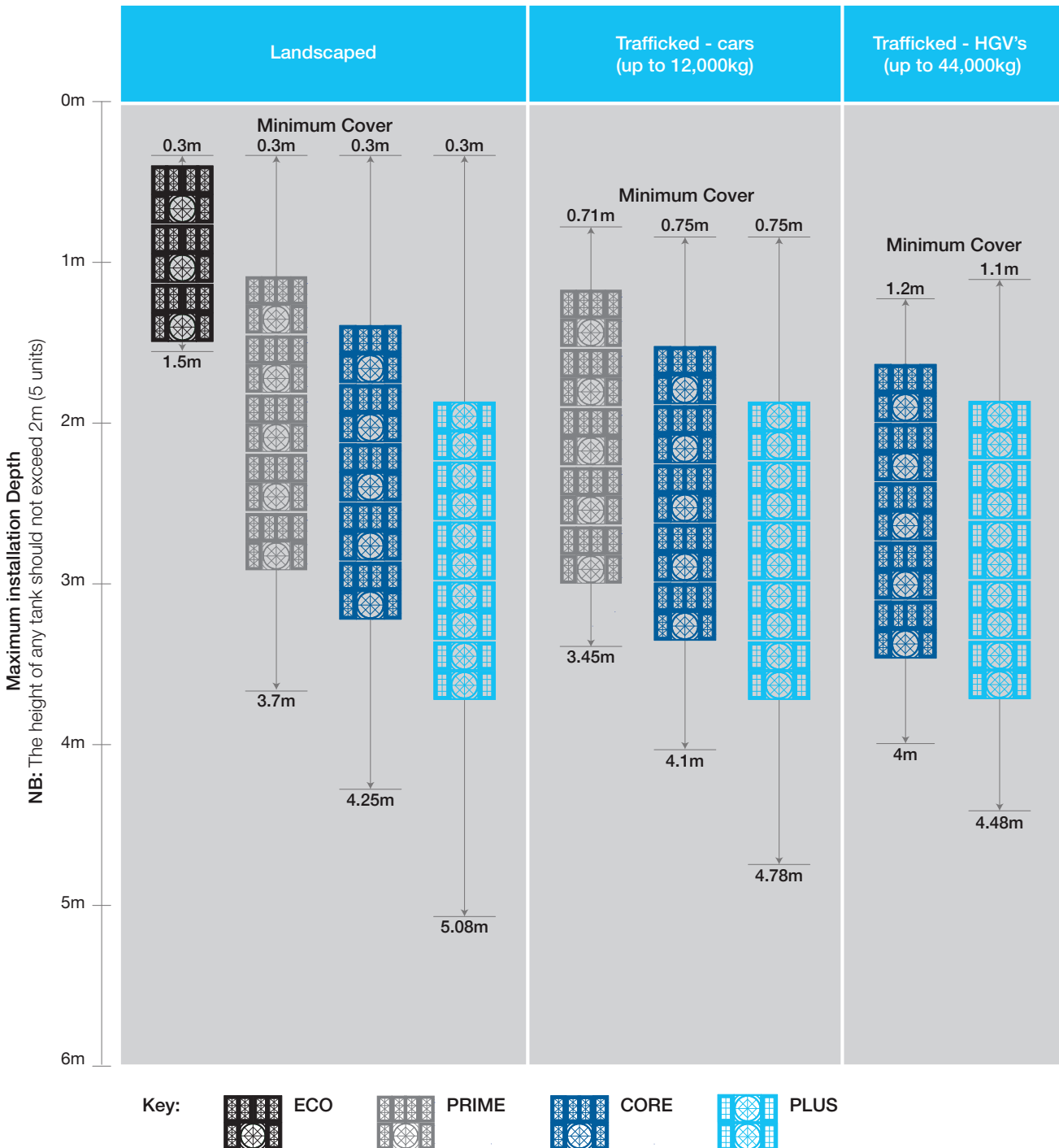

Note: The AquaCell units can also be used in combination with each other, see page 18 for details.

Design Guidance AquaCell Units

Mix and match

Although all AquaCell units have identical dimensions, and a high nominal void ratio of 95%, they are manufactured to perform at a range of depths, dependent on soil type, angle of shearing resistance, loading and ground water levels. For optimum performance the units can be mixed and matched (in layers) to value engineer the most effective design (in cost and performance terms) for each installation. For example, in a landscaped application if you needed to install a tank or soakaway that is deeper than 1.5m, you could install layers of AquaCell Prime underneath the AquaCell Eco. See below illustrations showing examples of how the AquaCell units can be mix and matched together. For advice on how to optimise a tank or soakaway design using more than one type of AquaCell please contact Wavin Technical Design.

Note: AquaCell Eco cannot be used directly with AquaCell Plus therefore there must be a layer of either AquaCell Prime or Core between them.

Typical examples of Mix & Match with AquaCell

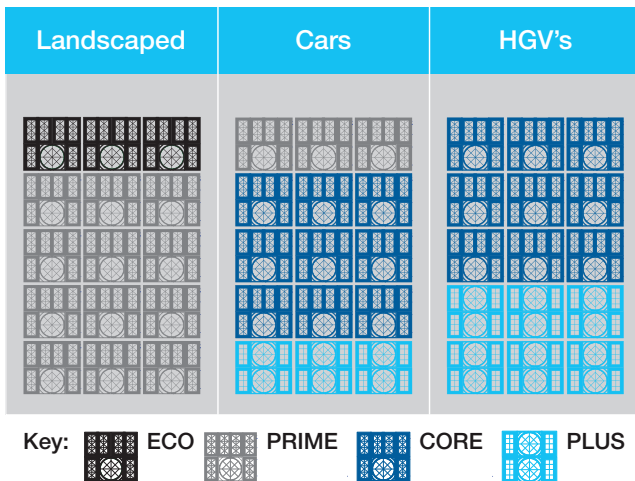

Brick bonding – for extra stability

When assembling a geocellular structure that comprises two or more layers, it is recommended that AquaCell units are placed in a 'brick-bonded' configuration for extra stability.

This helps minimise continuous vertical joints in the assembly, and gives the structure extra stability.

A significant advantage of AquaCell unit design is that brick bonding placement does not require extra connectors.

All four AquaCell units may be placed in this way, unless inspection channels and cleaning access are required using AquaCell Plus.

AquaCell Plus units incorporate integral inspection channels. These are designed for combined alignment to create viewing tunnels at the base of an assembled structure (see page 13).

Example of AquaCell being brick bonded

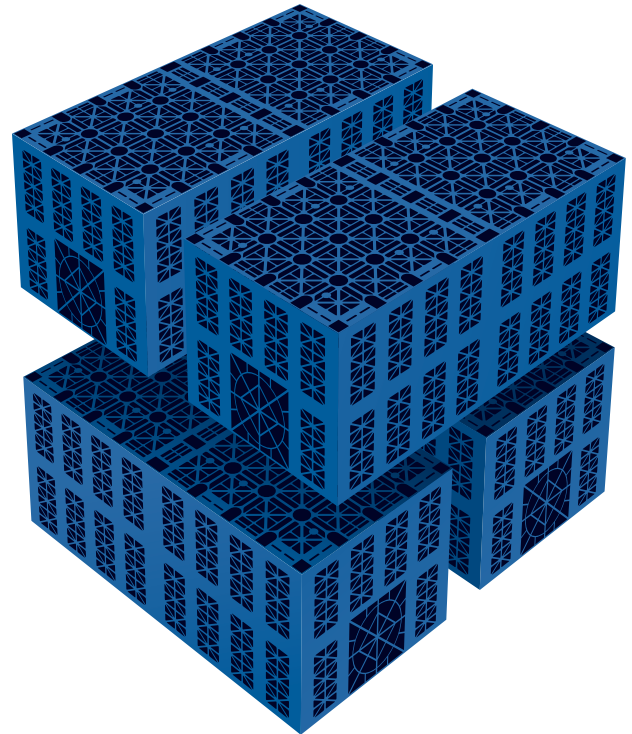

Installation Guidance

AquaCell Units

AquaCell Prime, Core and Plus: Construction Loads

Construction plant such as excavators can impose significant loads on any AquaCell unit. The following guidelines should be observed:

- ⦿ Tracked excavators (not exceeding 21 tonnes weight) should be used to place fill over the AquaCell units when the geotextile or geomembrane wrapping has been completed
- ⦿ At least 300mm of fill should be placed before the excavators or trucks delivering the backfill are allowed to traffic over the installed units
- ⦿ Compaction plant used over the AquaCell units should not exceed 2300kg/metre width. This will allow the compaction of Type 1 sub-base in 150mm layers over the units in accordance with the Specification for Highways Works
- ⦿ All other construction plant should be prevented from trafficking over the system once it is installed and surfacing completed, unless a site specific assessment demonstrates that it is acceptable
- ⦿ In particular cranes should not be used over, or place their outriggers over the system

AquaCell Eco: Construction Loads

As AquaCell Eco is designed for landscaped and non-loaded applications, certain precautions are recommended on site to prevent damage to the units through excess loading.

Manual assembly

Whilst assembling the tank, it may be necessary to walk on top of previously laid AquaCell units. Therefore care should be taken not to damage the edges of the units.

Backfilling

When backfilling AquaCell Eco installations:

- ⦿ Machines placing the material must be located OFF the units
- ⦿ Only light compaction should be applied to the material
- ⦿ Backfill with suitable, stone-free, as-dug material
- ⦿ First layer should be 300mm thick before using any compaction plant
- ⦿ NO vibratory mechanism should be used for compacting this first layer
- ⦿ Compaction plant must not exceed 2300kg per metre width

Construction traffic on site

Once backfilled, if construction plant (e.g. excavators or loaders) are likely to run over the installation, ensure that:

- ⦿ MINIMUM protective cover should be 500mm well-compacted granular material
- ⦿ Only tracked excavators can be used and MUST NOT weigh more than 14 tonnes.
- ⦿ HGVs MUST NOT run over installed AquaCell Eco units

Manual assembly

All ancillaries and adaptors (see pages 36-39) can be used with either the AquaCell Eco, Prime, Core or Plus units, except the 225mm Flange Adaptor (6LB106) which must only be used with AquaCell Prime, Core or Plus.

The 150mm Flange Adaptor (6LB104) should only be used when constructing an air vent on the top surface of an AquaCell Eco unit. The adaptor should not be used to connect inlet pipes to the side of an Eco unit.

Installation AquaCell Units

Typical Soakaway Installation Method

Typical installation procedure

1. Excavate the trench to the required depth ensuring that the plan area is slightly greater than that of the AquaCell units.
2. Lay 100mm bed of coarse sand or non angular granular material, level and compact.
3. Lay the geotextile* over the base and up the sides of the trench.
4. Lay the AquaCell units parallel with each other. In multiple layer applications, wherever possible, continuous vertical joints should be avoided. AquaCell units can be laid in a 'brick bonded' formation (i.e. to overlap the joints below) – see page 18. For single layer applications use the AquaCell Clips and for multi layer use the AquaCell Clips and the AquaCell Shear Connectors (vertical rods).
5. Fix the Adaptors to the AquaCell units as required and connect pipework.
6. In order to prevent silt from entering the tank, clogging inlet pipework and reducing storage capacity, it is recommended that the Domestic Silt Trap (6LB300) or the standard Silt Trap (6LB600) is installed prior to the inlet pipework – see page 26 for installation guidelines.
7. Wrap and overlap the geotextile covering the entire AquaCell structure.
8. Lay 100mm of coarse sand or non angular granular material between the trench walls and the AquaCell structure and compact.
9. Lay 100mm of coarse sand or non angular granular material over the geotextile and compact.
10. Backfill with suitable material.
11. Rainwater from roof areas may discharge directly into the soakaway but rainwater from car parks must discharge through a catchpit manhole and/or a petrol interceptor.

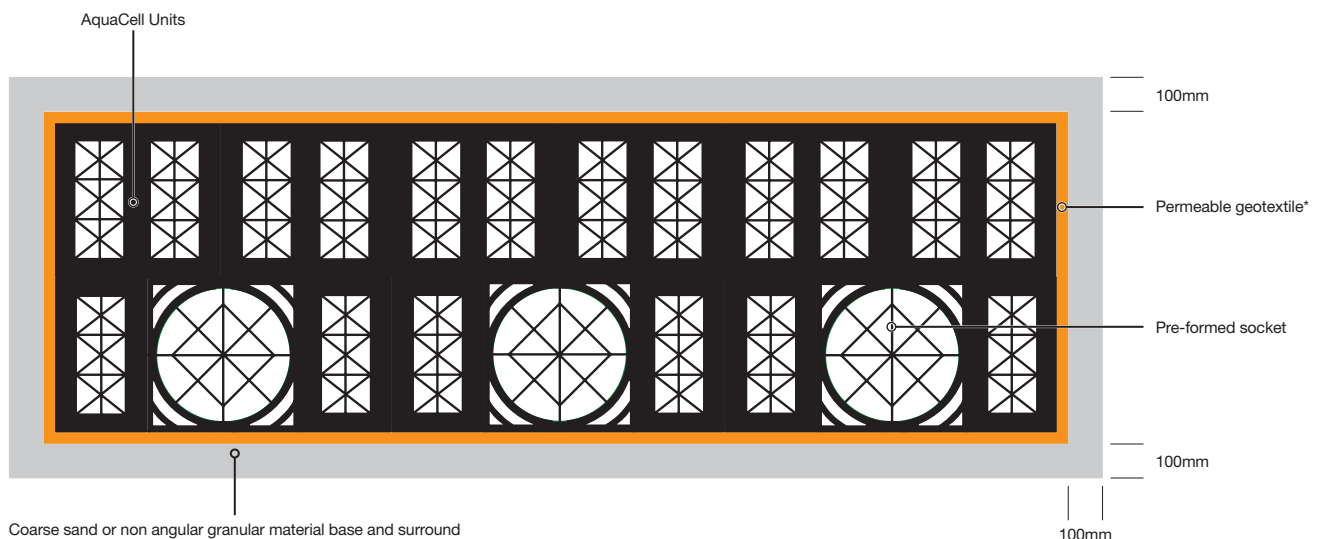

Example shows the use of AquaCell Eco. However, a soakaway can also be installed as shown using either of the other versions of AquaCell units (Prime, Core or Plus) as appropriate.

**The geotextile should be selected according to specific site conditions. Typically, however, a 300g non-woven material will be suitable. Specialist advice should be sought if surrounding soil characteristics exhibit a high degree of fines/low infiltration capacity and/or there is a high risk of damage from ground contaminants.*

Typical Storage Tank Installation Method

Typical installation procedure

1. Excavate the trench to the required depth ensuring that the plan area is slightly greater than that of the AquaCell units.
2. Lay 100mm bed of coarse sand, level and compact.
3. Lay the geotextile over the base and up the sides of the trench.
4. Lay the geomembrane on top of the geotextile over the base and up the sides of the trench.
5. Lay the AquaCell units parallel with each other. In multiple layer applications, wherever possible, continuous vertical joints should be avoided. AquaCell units can be laid in a 'brick bonded' formation (i.e. to overlap the joints below) – see page 18. For single layer applications use the AquaCell Clips and for multi layers use the AquaCell Clips and the AquaCell Shear Connectors (vertical rods).
6. Wrap the geomembrane around the AquaCell structure and seal to manufacturers recommendations.*
7. If side connections into the AquaCell units is required, (other than the preformed socket), use the appropriate Flange Adaptor (6LB104 or 6LB106). Fix the flange adaptor to the unit using self-tapping screws. Drill a hole through the Flange Adaptor and connect the pipework. (6LB106 should not be used with AquaCell Eco).
8. In order to prevent silt from entering the tank, clogging inlet pipework and reducing storage capacity, it is recommended that the Domestic Silt Trap (6LB300) or the standard Silt Trap (6LB600) is installed prior to the inlet pipework – see page 22 for installation guidelines.
9. Wrap and overlap the geotextile covering the entire AquaCell structure, to protect the geomembrane.
10. Lay 100mm of coarse sand between the trench walls and the AquaCell units and compact.
11. Lay 100mm bed of coarse sand over the geotextile and compact. Backfill with suitable material. .

NB: A storage tank must be vented, and it is recommended that one vent pipe, 110mm in diameter is provided per 7,500 square metres of impermeable catchment area on a site, see page 22 for design.

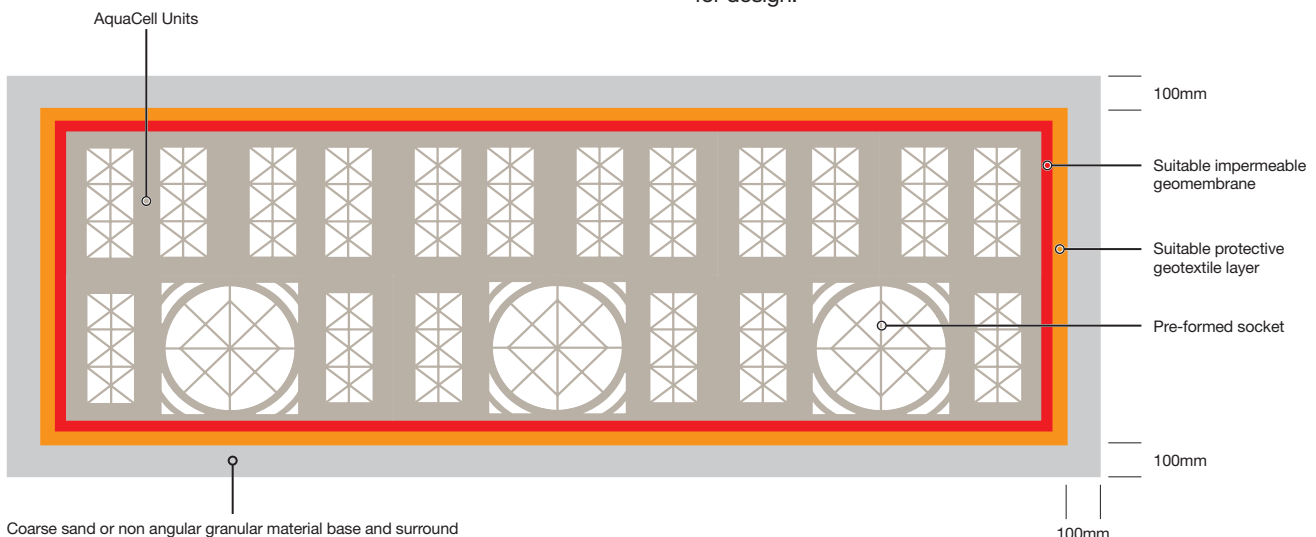

Example shows the use of AquaCell Prime. However, a storage tank can also be installed as shown using any of the other versions of AquaCell units (Eco, Core or Plus) as appropriate.

*For large scale, deep installations a 1mm thick geomembrane is recommended and joints should be sealed using proprietary welding techniques. For further details contact Wavin Technical Design.

Installation AquaCell Units

Silt Trap and Air Vent Termination

Silt Trap

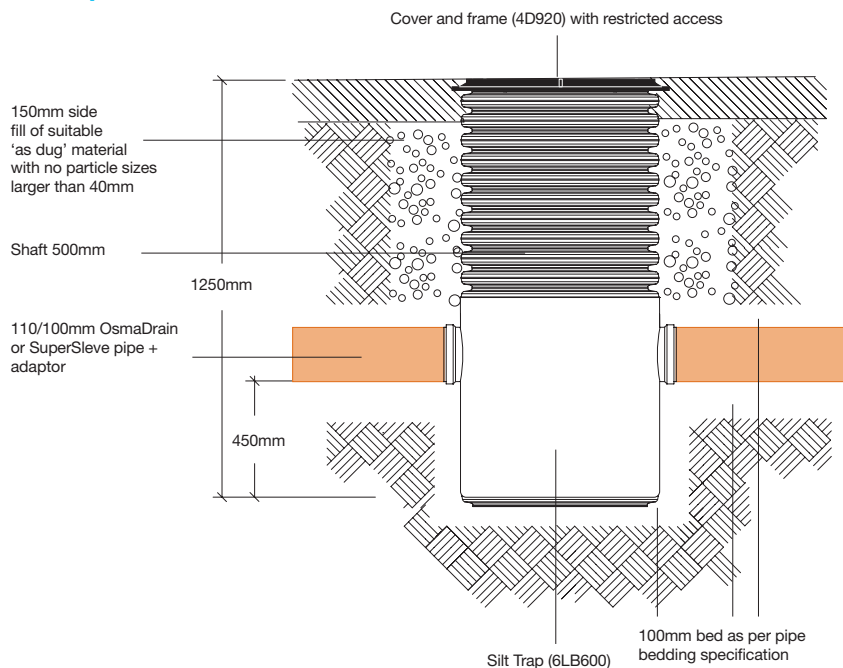

Typical installation procedure

1. Place the Silt Trap (6LB600) on a minimum of 100mm bed as per pipe bedding specification. Ensure that the trap is as close to the AquaCell unit as possible and in a suitable position to allow pipework connection.
2. Connect the relevant pipework in accordance with standard pipe installation guidelines.
3. Surround the sides of the Silt Trap with 150mm of 'as dug' material, with no particle sizes larger than 40mm.
4. Fit relevant cover and frame.

NOTE: When surrounded by a concrete plinth (150mm x 150mm) the 4D920 Cover and Frame can be used in situations with a loading of up to 50kN (5 tonne).

Typical Air Vent design

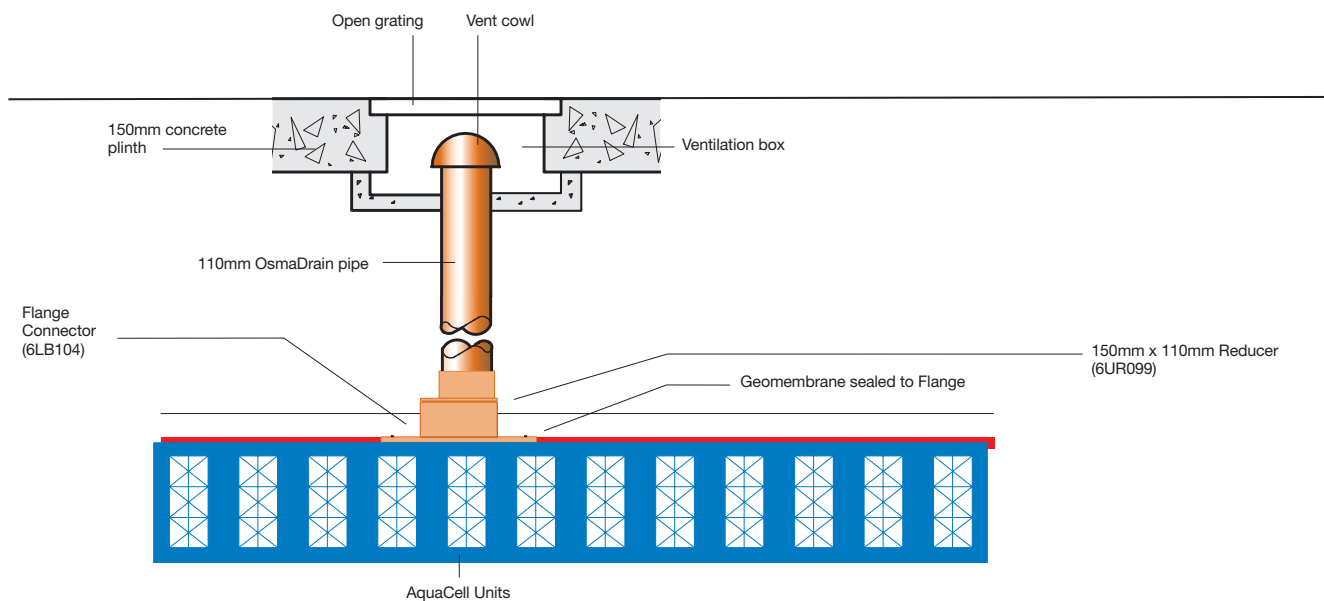

NOTE: It is recommended that all connections and air vent installations in storage applications (using geomembrane) are made using a Flange Adaptor.

Adhesive or double sided tape should be used between the geomembrane and the flange plate to ensure a watertight seal.

NOTE: It is recommended that one vent pipe, 110mm in diameter, is provided per 7,500 square meters of impermeable catchment area on a site. Please contact Wavin Technical Design for further details.

Typical Details AquaCell Units

Top Connection for Air Vent

Connect into the top of the AquaCell unit, using Flange Adaptor.

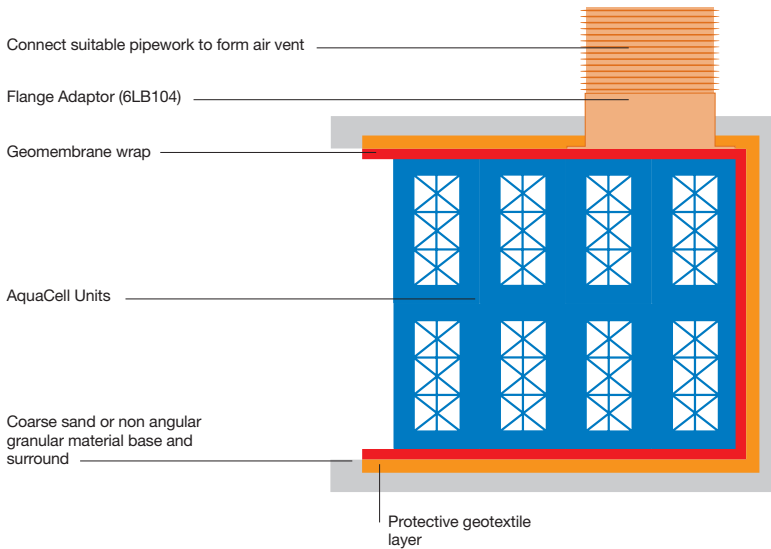

Typical installation procedure

1. Fix Flange Adaptor to the AquaCell unit with self tapping screws.
2. Cut through the geomembrane.
3. Insert pipework into Flange Adaptor to form air vent.

Side Connection for Air Vent

Connect into the side of the AquaCell tank unit using standard Reducer.

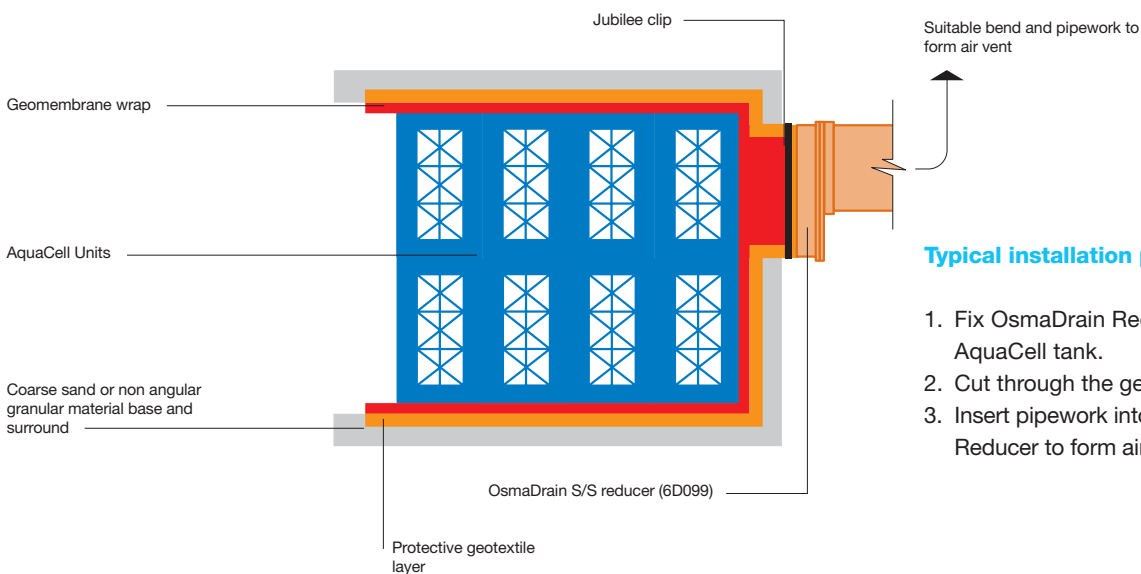

Typical installation procedure

1. Fix OsmaDrain Reducer to the AquaCell tank.
2. Cut through the geomembrane.
3. Insert pipework into OsmaDrain Reducer to form air vent.

Typical Details AquaCell Units

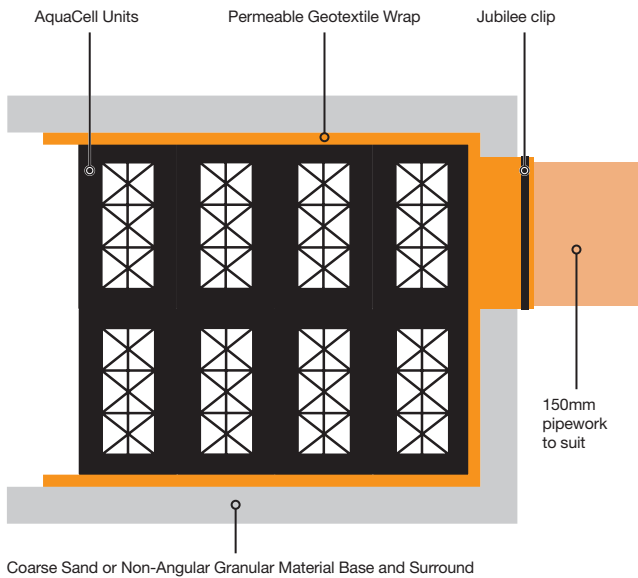

Connections to AquaCell Units

Connection for soakaway application using either the pre-formed socket (as shown below) or standard adaptors into pre-formed socket*.

*NOTE: For pipework other than 160mm OsmaDrain, these adaptors can be used to connect to the following:

- ⦿ 6TW141: TwinWall S/S Adaptor connects to 150mm TwinWall
- ⦿ 6D099: OsmaDrain Adaptor connects to 110mm OsmaDrain
- ⦿ 4D916: OsmaDrain PE Adaptor connects to 160mm OsmaDrain
- ⦿ 6UR141: UltraRib S/S Adaptor connects to 150mm UltraRib
- ⦿ 6D129: OsmaDrain S/S Adaptor connects to 150mm SuperSleve clay. (Use an appropriate reducer, as required, e.g. 6D099)

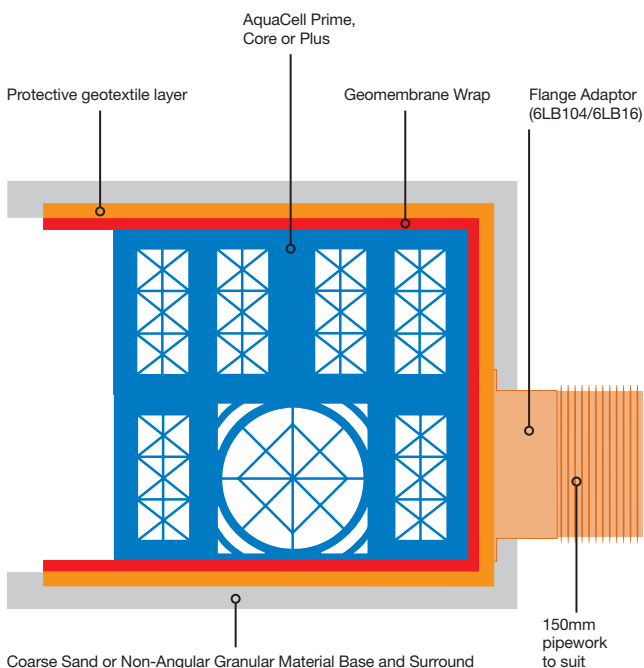

Connection for storage application using Flange Adaptor at points other than pre-formed socket, (for AquaCell Prime, Core or Plus).

Installation procedure

1. Fix Flange Adaptor to the AquaCell unit with self tapping screws.
2. Cut through the geomembrane.
3. Insert pipework into Flange Adaptor.

*NOTE: AquaCell Eco is not suitable for side connection using a Flange Adaptor.

Connection Configurations

The connections shown here in schematic form, are the typical options used to connect AquaCell units to control chambers. They provide a controlled feed into and out of the AquaCell units, and are used for either infiltration or attenuation schemes.

Manifold connection

Using standard pipes and fittings

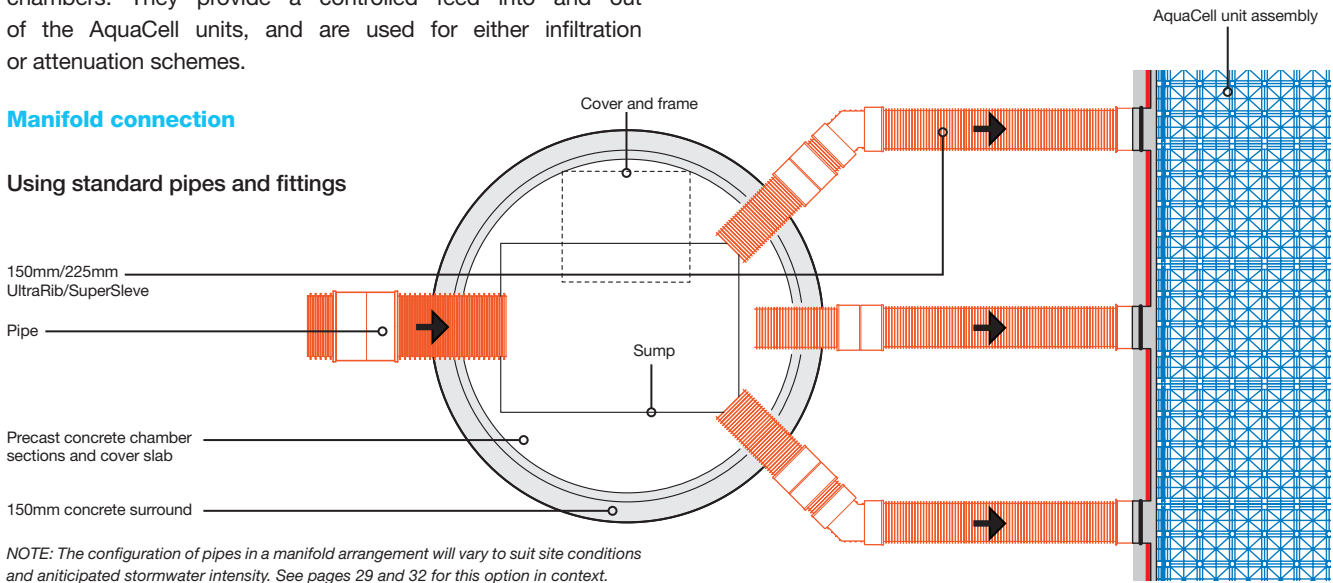

NOTE: The configuration of pipes in a manifold arrangement will vary to suit site conditions and anticipated stormwater intensity. See pages 29 and 32 for this option in context.

Box connection

Using AquaCell units for fast water transfer

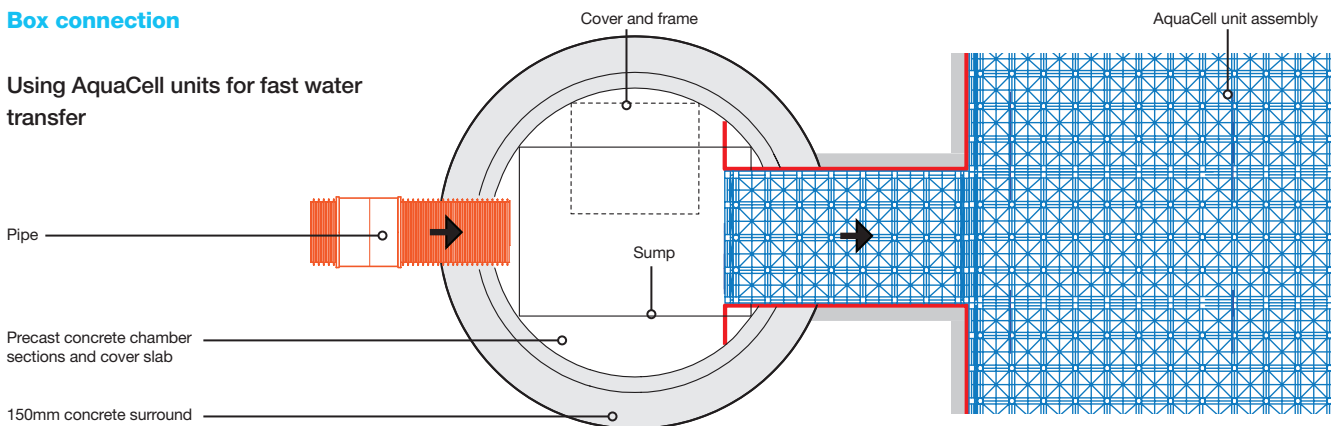

NOTE: See pages 28 and 31 for this option in context.

Central pipe connection

Using standard perforated Wavin TwinWall pipe and fittings

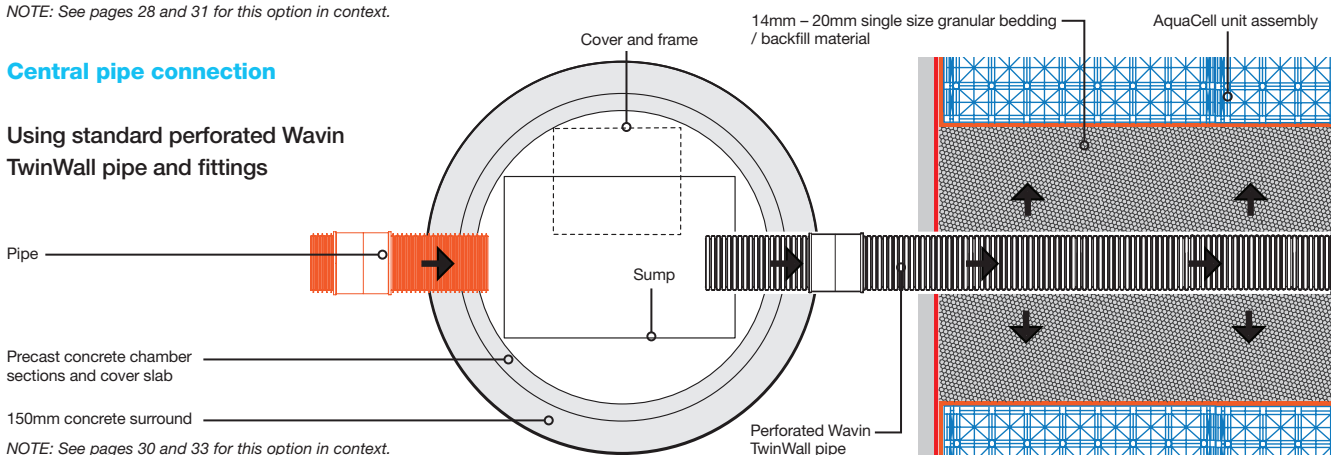

NOTE: See pages 30 and 33 for this option in context.

Typical Details AquaCell Units

Soakaway – Non-Traffic Loading

Soakaway

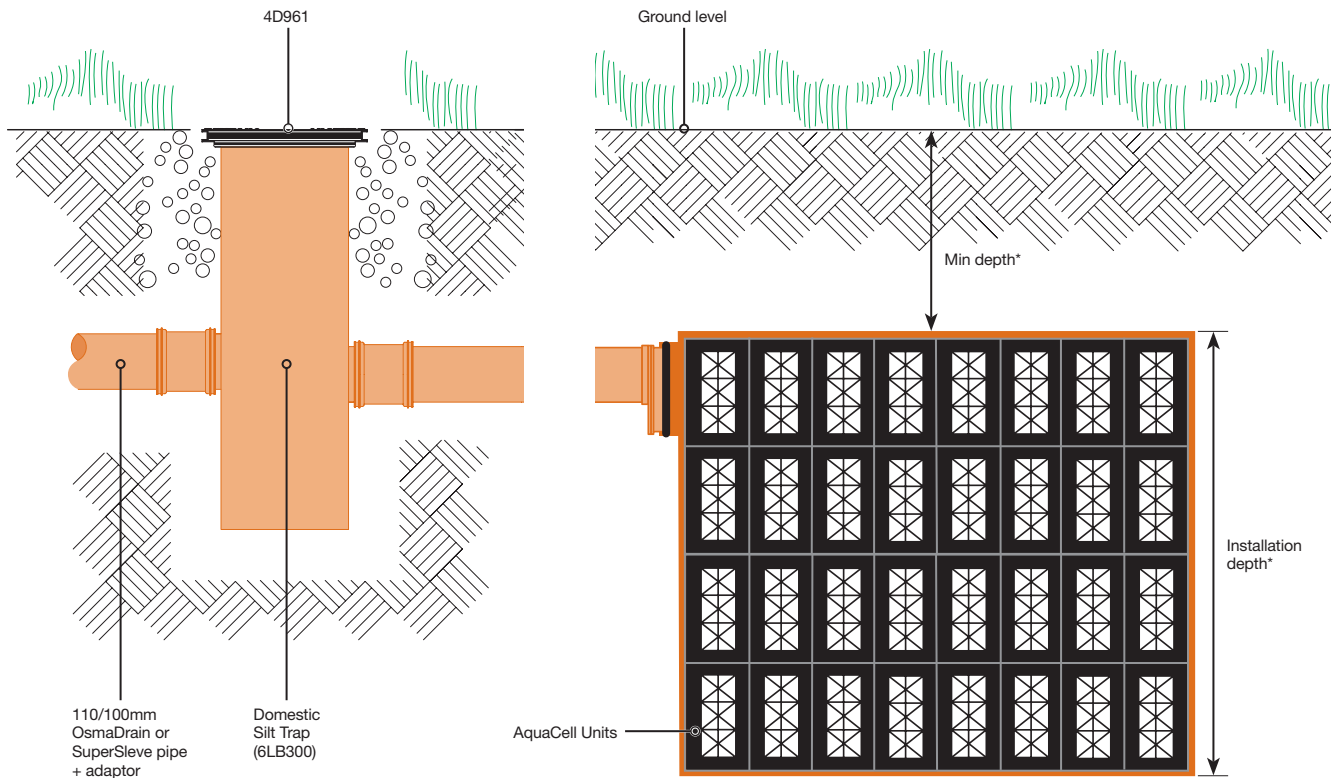

Trench soakaway

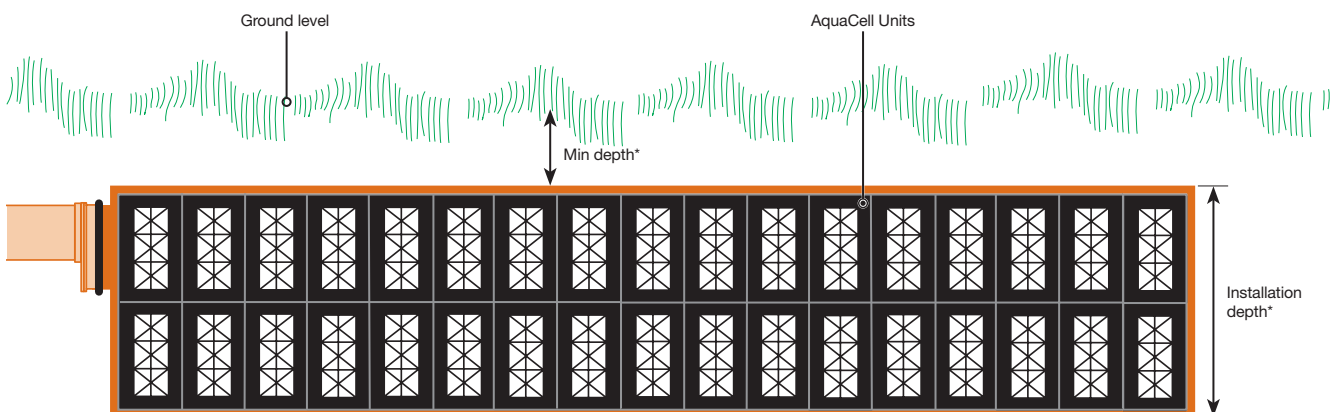

Notes

1. Soakaways should be sited at least 5m away from the building (Ref BS EN 752-4).
2. The exact size and shape of the soakaways are to be determined once all the necessary calculations have been produced.

*For information regarding cover depths and installation depths, see page 17.

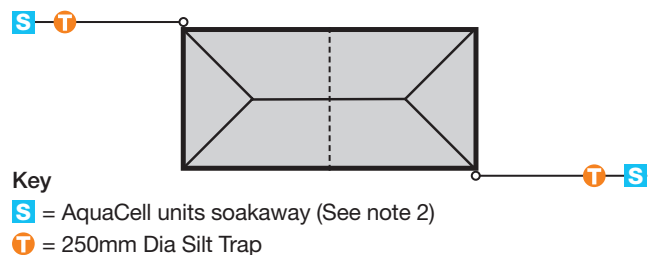

Soakaway – Traffic Loading

Soakaway

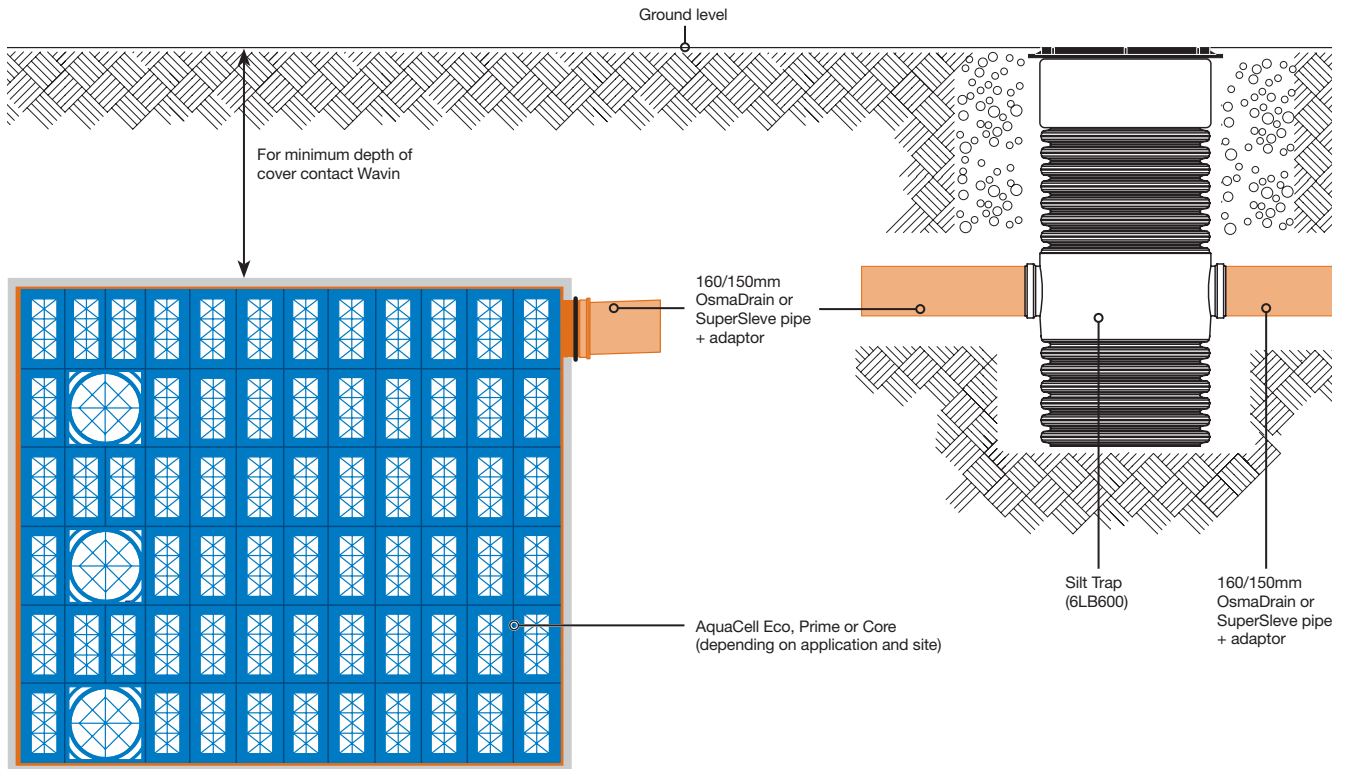

Typical Details AquaCell Units

On-Line Storage – Box Feed

Long section

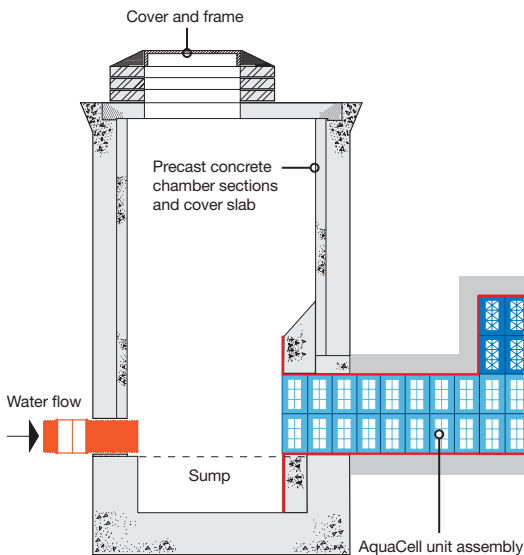

Typical vent detail

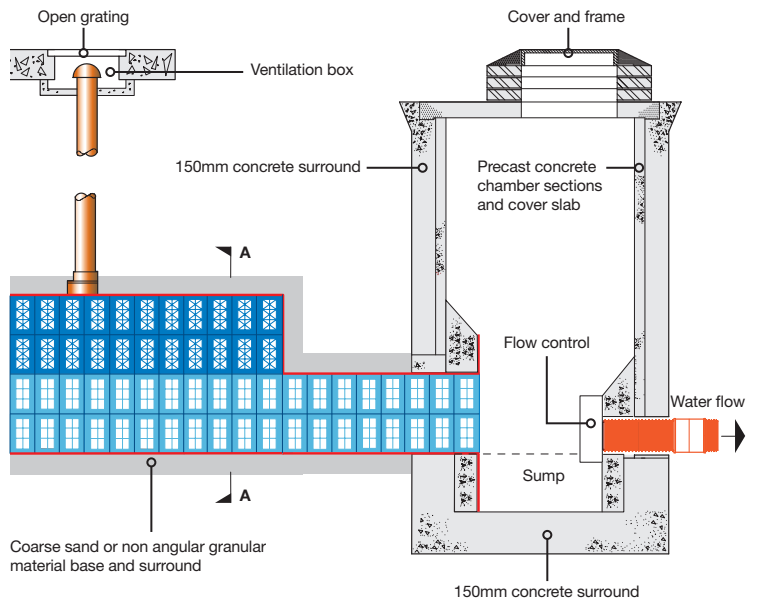

Plan

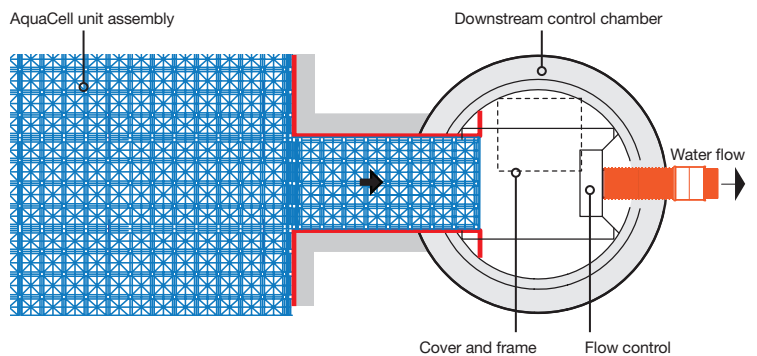
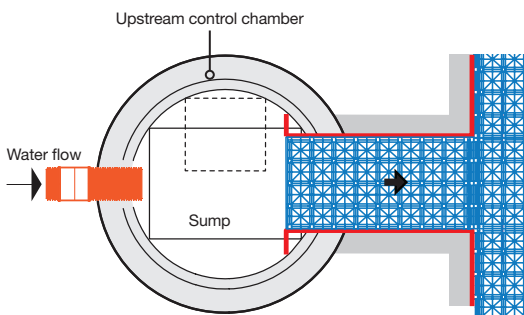

Cross section A-A

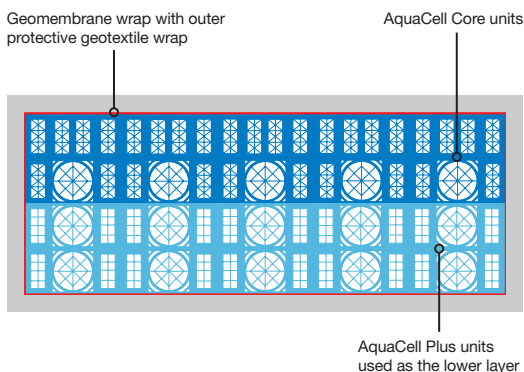

What happens to the water?

1. The water level in the upstream control chamber rises.
2. Then, during a storm event, the AquaCell storage assembly quickly fills with water via the AquaCell feed connection.
3. After storm event, water flows back out of the AquaCell storage assembly, finding its own level, and into the downstream control chamber.
4. The water then flows through the vortex flow control valve.

On-Line Storage – Manifold Feed

Long section

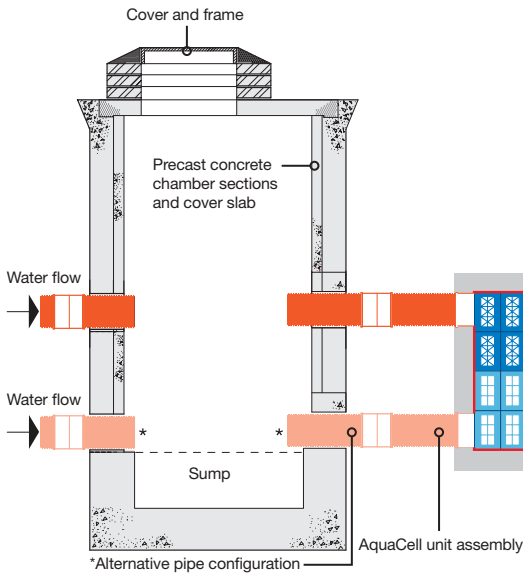

Typical vent detail

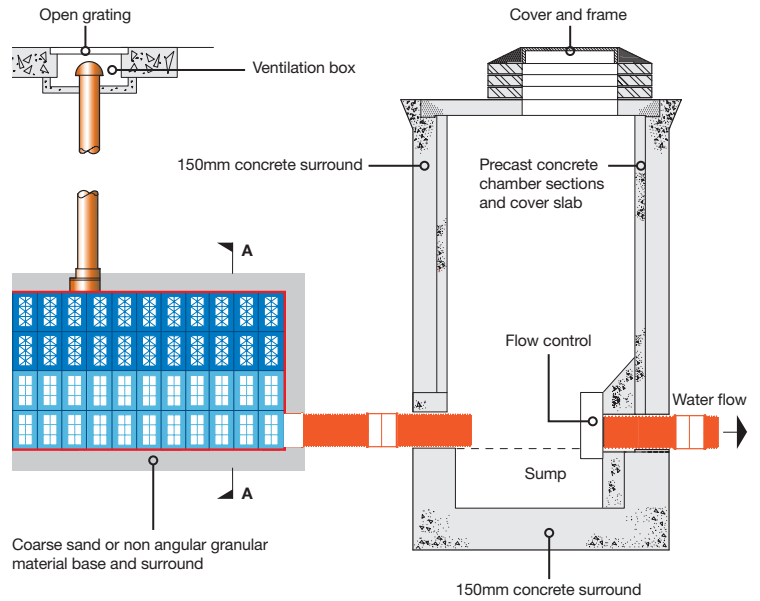

Plan

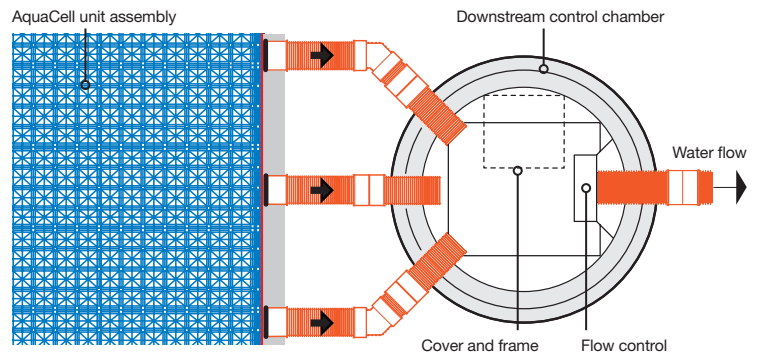
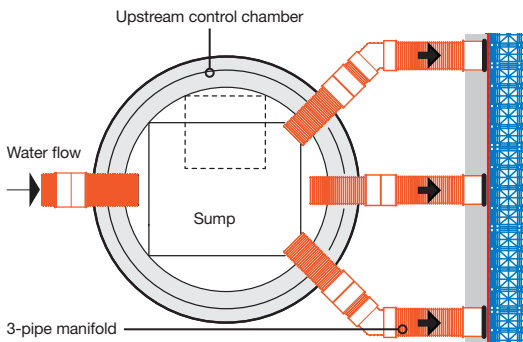

Cross section A-A

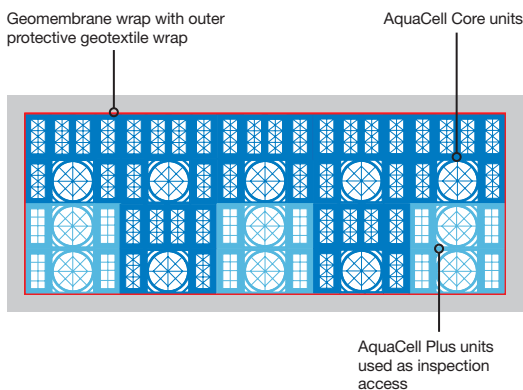

What happens to the water?

1. The water level in the upstream control chamber rises.
2. During a storm event, the AquaCell storage assembly fills with water via the manifold feed connection.
3. After storm event, water flows back out of the AquaCell storage assembly, finding its own level, and into the downstream control chamber.
4. The water then flows through the vortex flow control valve.

Typical Details AquaCell Units

On-Line Storage – Central Pipe Feed

Long section

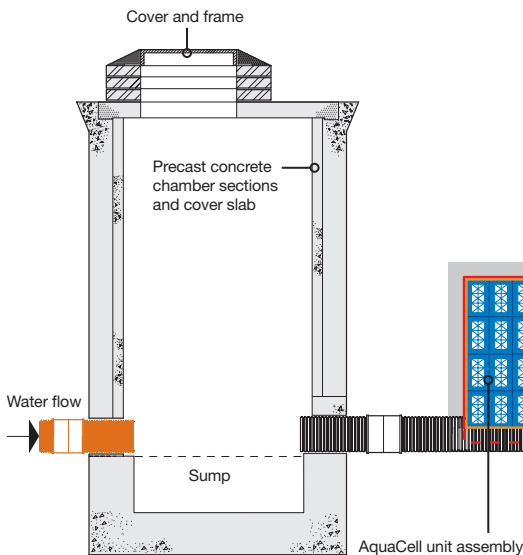

Typical vent detail

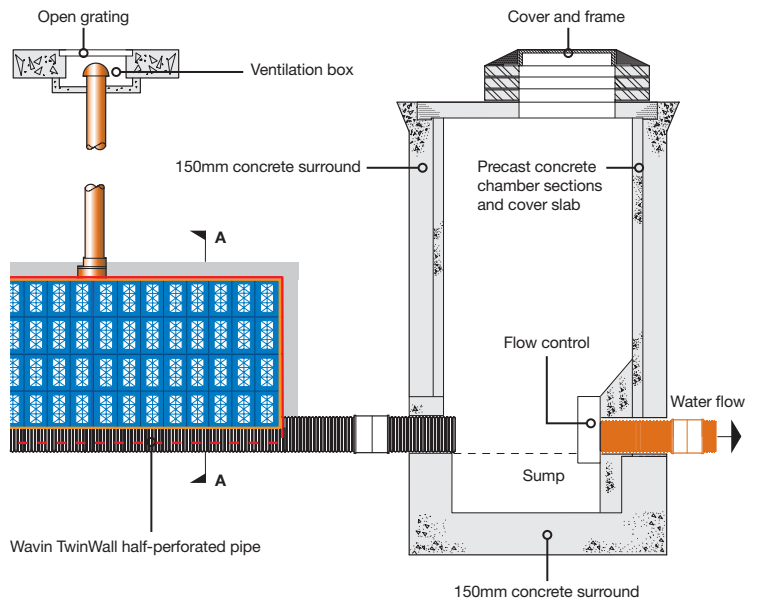

Plan

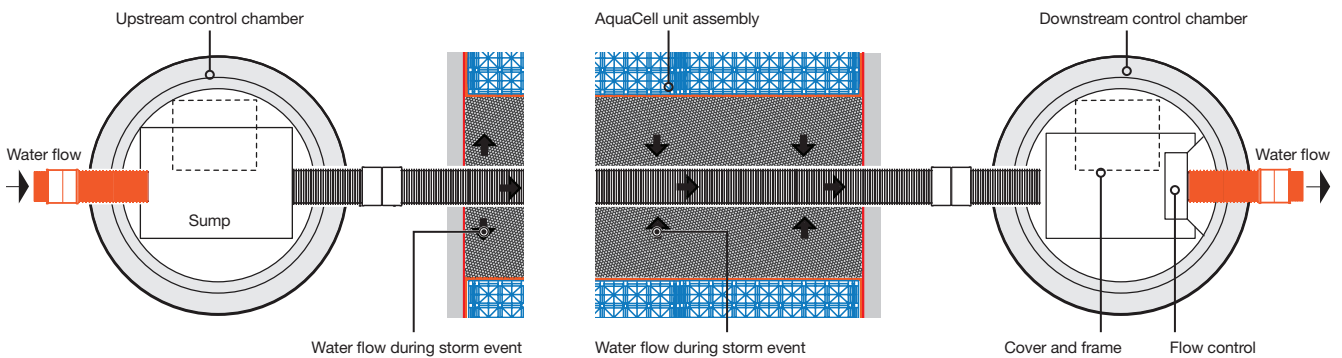

Cross section A-A

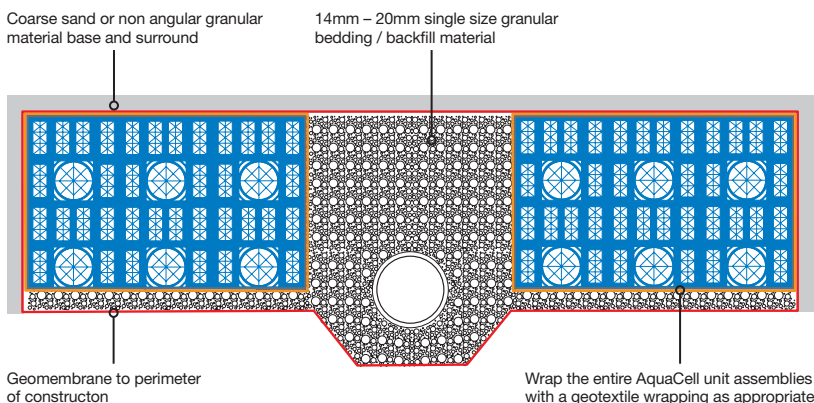

What happens to the water?

1. The water level in the upstream control chamber rises.
2. AquaCell storage assemblies fill with water via the central pipe connection and percolate's through the granular bedding material.
3. After storm event, water flows back out of the AquaCell storage assemblies, finding its own level, and into the downstream control chamber.
4. The water then flows through the vortex flow control valve.

Off-Line Storage – Box Feed

Long section

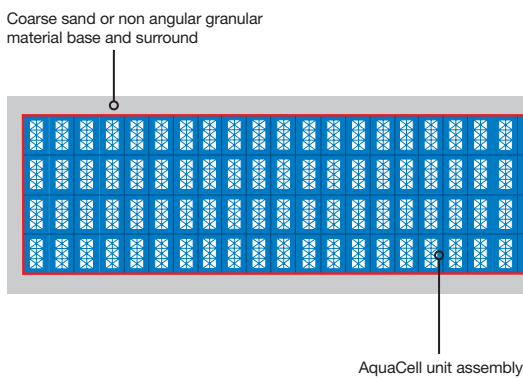

Typical vent detail

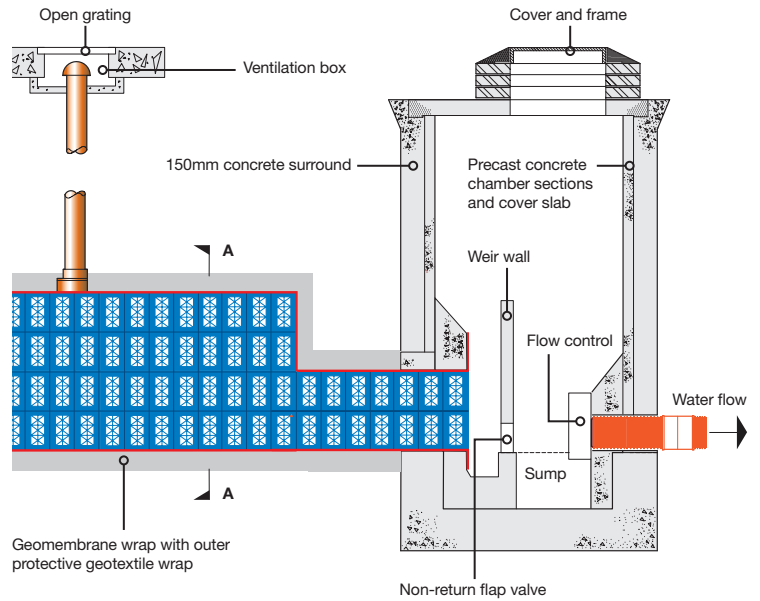

Plan

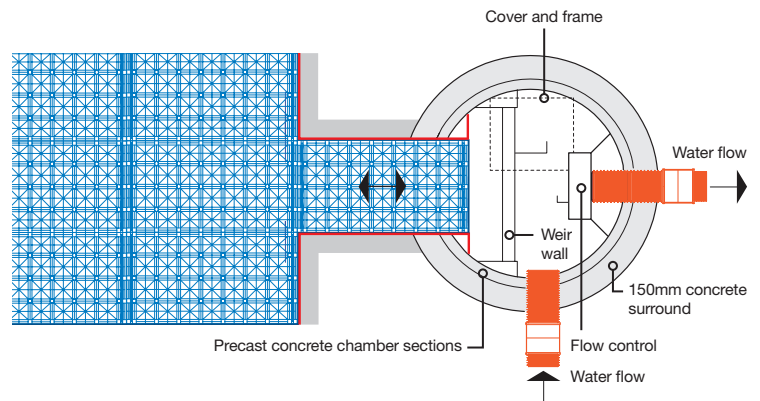
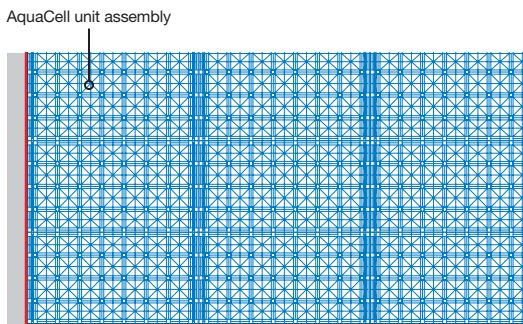

Cross section A-A

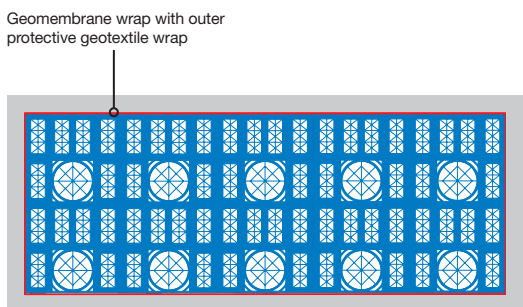

What happens to the water?

1. Control chamber fills with water, up to the top of the weir wall.
2. The water overflows the weir wall and enters the AquaCell storage assembly via the AquaCell connection.
3. The AquaCell storage assembly fills with water.
4. After storm event, water flows back out of the AquaCell storage assembly, finding its own level, and through the non-return flap valve at the bottom of the weir wall.
5. The water then flows through the vortex flow control valve.

Typical Details AquaCell Units

Off-Line Storage – Manifold Feed

Long section

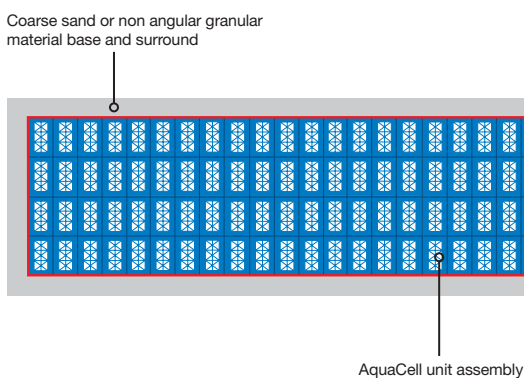

Typical vent detail

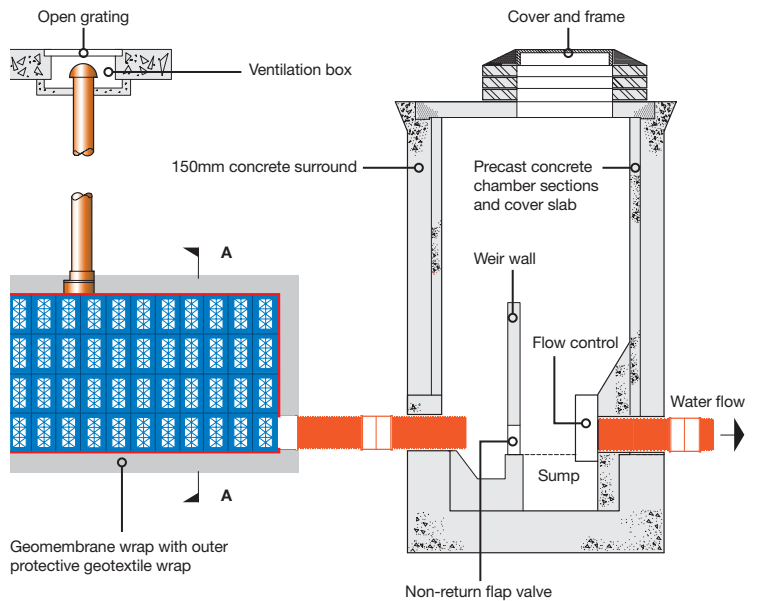

Plan

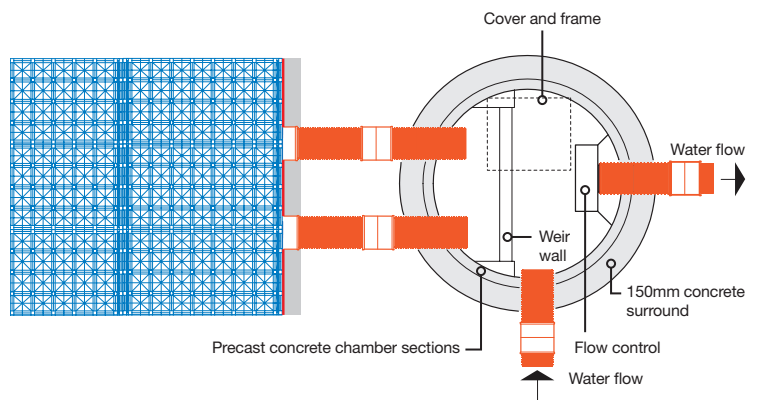
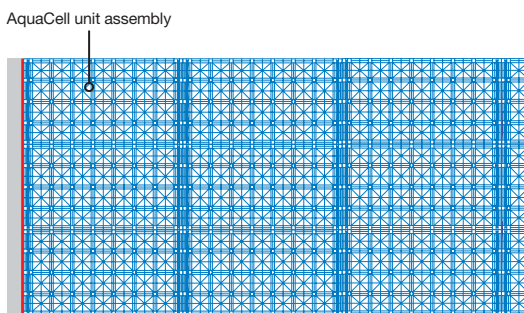

Cross section A-A

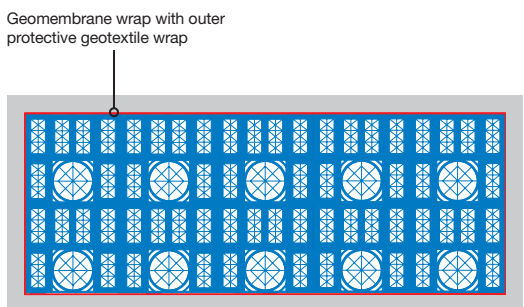

What happens to the water?

1. Control chamber fills with water, up to the top of the weir wall.
2. The water overflows the weir wall and enters the AquaCell storage assembly via the manifold connection.
3. The AquaCell storage assembly fills with water.
4. After storm event, water flows back out of the AquaCell storage assembly, finding its own level, and through the non-return flap valve at the bottom of the weir wall.
5. The water then flows through the vortex flow control valve.

Off-Line Storage – Central Pipe Feed

Long section

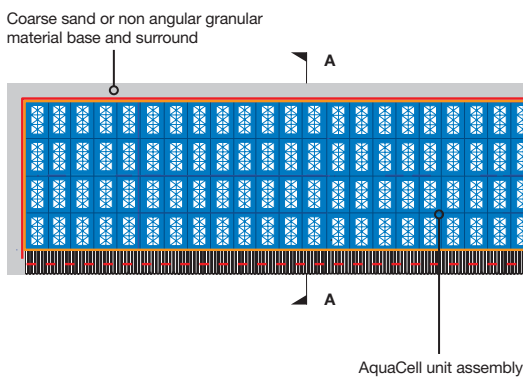

Typical vent detail

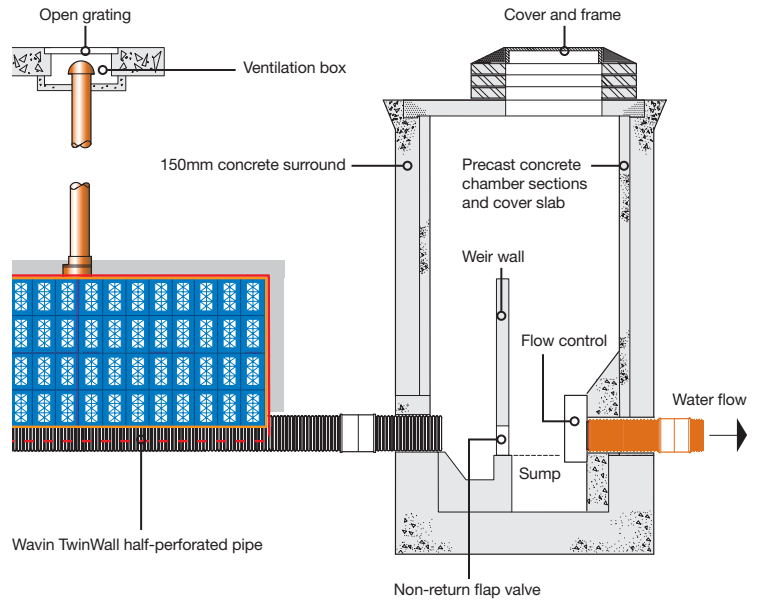

Plan

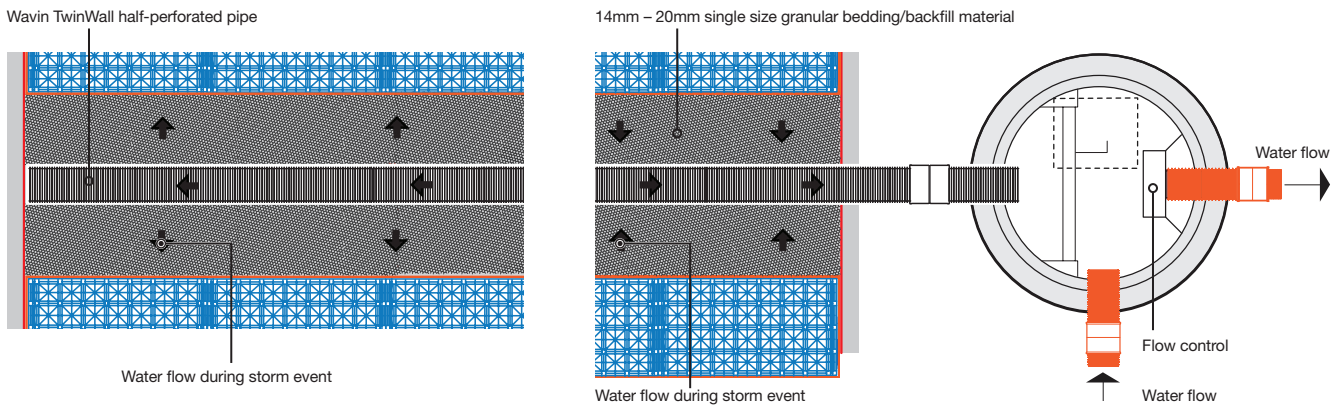

Cross section A-A

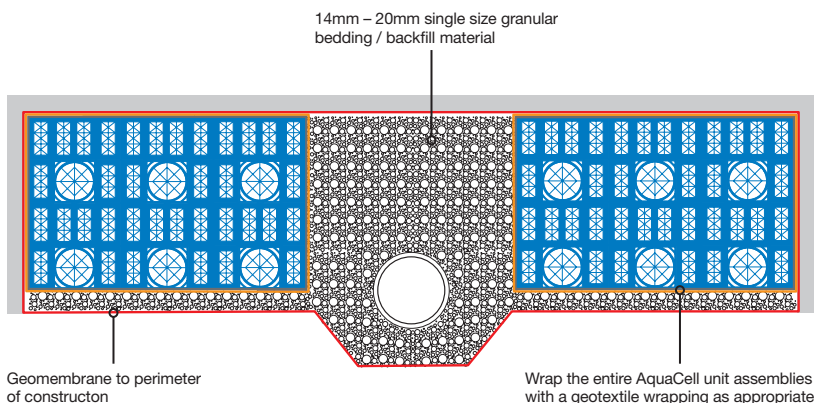

What happens to the water?

1. Control chamber fills with water, up to the top of the weir wall.
2. The water overflows the weir wall and enters the AquaCell storage assemblies via the central pipe connection and percolate's through the granular bedding material.
3. The AquaCell storage assembly fills with water.
4. After storm event, water flows back out of the AquaCell storage assemblies, finding its own level, and through the non-return flap valve at the bottom of the weir wall.
5. The water then flows through the vortex flow control valve

Typical Details AquaCell Units

Soakaway or Storage Tank – With Silt Trap

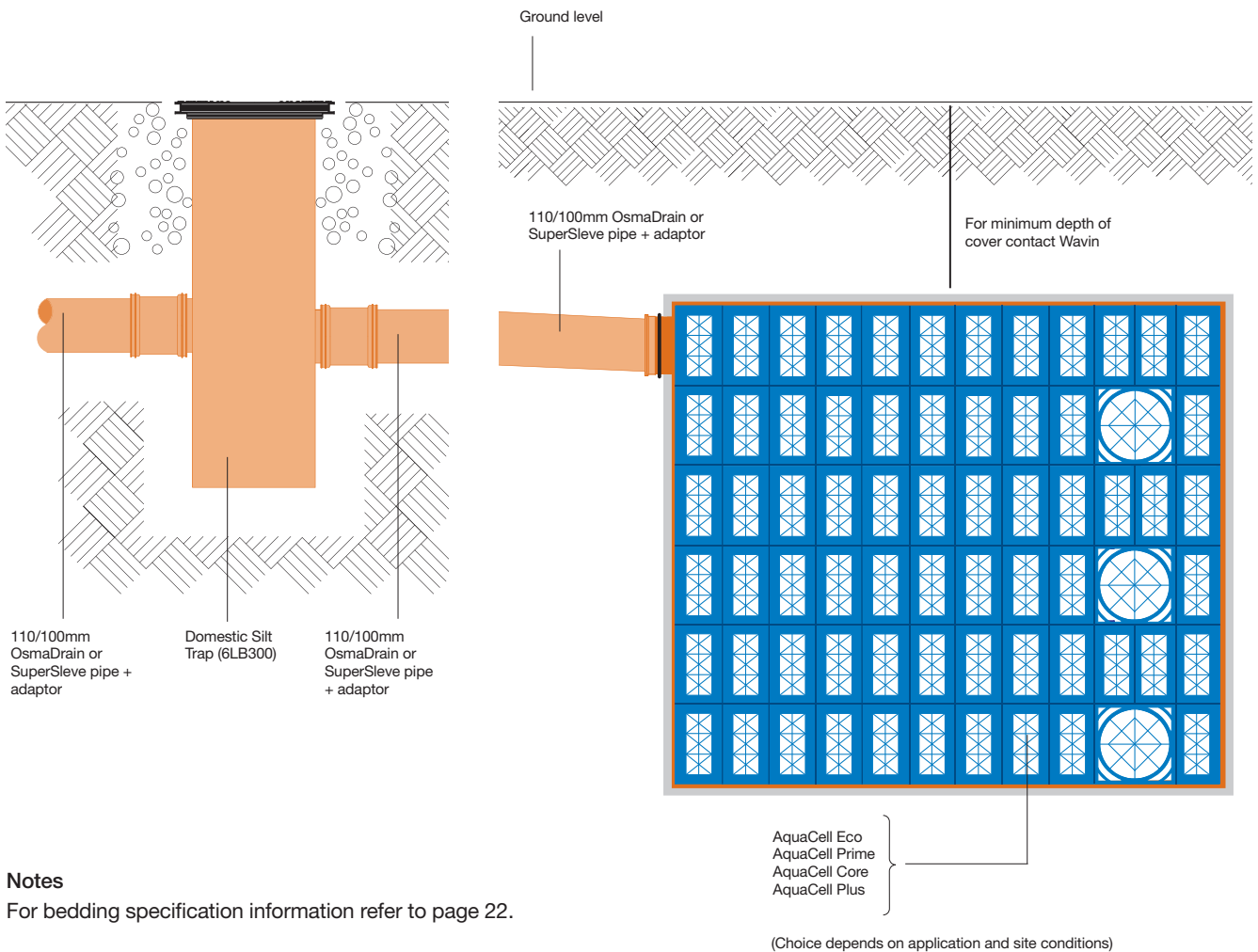

Notes

For bedding specification information refer to page 22.

The silt trap can be used in conjunction with a soakaway (as shown) or a storage tank.

Wavin Stormwater Management AquaCell Systems

To Achieve Optimum Stormwater Management

The Wavin Stormwater Management System represents a combination of specialist expertise and technology from Wavin. This is specifically focused on achieving the optimum solution for each project requiring effective and sustainable management of stormwater.

Such a solution may be entirely based on a tailored combination of our engineered systems.

In other cases, Wavin Stormwater Systems can be integrated with 'soft' SuDS techniques, such as ponds and swales, to help achieve the optimal solution.

Other Wavin Stormwater Systems

Oil Separators

A comprehensive range of NS Oil Separators, tested to EN 858 Class 1 standard and complying with PPG-3 legislation for England and Wales.

Channel Drainage

Environmentally-friendly polyester concrete systems to cover all EN 1433 load classes. With outstanding chemical resistance and low water absorption:

- ⦿ Medium duty range for applications up to C250
- ⦿ Heavy duty range for D400 / F900 application

Plastic Pervious Paving

High performance, plastic pervious paving system, for use in all types of Sustainable Drainage systems (SuDS).

- ⦿ AquaGrid 50 – for use in landscape projects
- ⦿ AquaGrid 75 – for use in car parking areas

Flow Control Valves

The Wavin+Mosbaek range of vortex flow control valves are manufactured from stainless steel and are custom-built to meet exact site requirements:

- ⦿ Tornado, Hurricane and Typhoon stainless steel flow control valves with no moving parts of power needs

Anti-flood Valves

- ⦿ Anti-Flood Valves that comply with EN 13546-1, and Part H1 – Sections 2.8-2.12 of Building Regulations

Below Ground Water Transportation

Wavin Stormwater installations can draw from an extensive choice of plastic and clay water conveyance systems, including:

- ⦿ OsmaDrain solid wall PVC-U pipe system
- ⦿ Structured wall plastic UltraRib and TwinWall pipe systems
- ⦿ SuperSleve and HepSeal clay pipe systems

Other options include perforated pipe for land drainage: WavinCoil plastic and HepLine clay – and a full range of Wavin Non-Entry Inspection Chambers.

Rainwater Re-Use

The Wavin Stormwater Water Range can also exploit stored rain water. These reduce the use of potable mains water for non-potable purposes.

The Wavin Stormwater Service

Precision and Performance

The Wavin Technical team are ready to contribute to any stormwater management project.

This may be at the very earliest stage – or when initial plans have already been developed. There are no pre-conditions with regards to you requesting Wavin to become involved.

We are ready to:

- ⦿ Originate project design
- ⦿ Comment on an existing design
- ⦿ Help validate a specification – or, where we see an opportunity to do so, to suggest how it may be enhanced
- ⦿ Check, clarify and confirm maximum cost-efficiency, performance capability and regulatory compliance

This involvement is a core part of the Wavin principle. It extends beyond the systems and components.

To discuss your stormwater management project, call 0844 856 5161 or email technical.design@wavin.co.uk.

Product Details

Supplementary Items

Silt Trap – Domestic – for non loaded applications

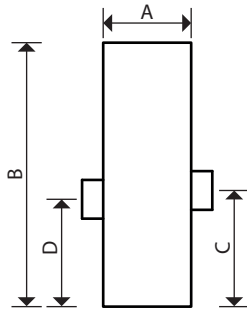

Domestic Silt Trap

- 250mm x 750mm depth
- With 110mm diameter inlet and outlet spigots
- For use with the 4D961 cover and frame

Material: PVC-U

Nominal Size (mm)	Part Number	Dimensions (mm)			
		A	B	C	D
-	6LB300	250	750	330	305

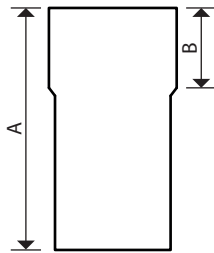

Extension Piece for 6LB300

- 250mm x 500mm depth (effective length = 335mm)

Material: PVC-U

Nominal Size (mm)	Part Number	Dimensions (mm)	
		A	B
-	6LB301	500	165

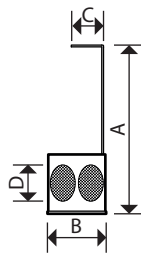

Silt Trap Bucket for 6LB300

- 200mm x 210mm depth

Material: PVC-U/Polypropylene

Nominal Size (mm)	Part Number	Dimensions (mm)			
		A	B	C	D
-	6LB302	597	208	114	127.5

Silt Trap – Trafficked

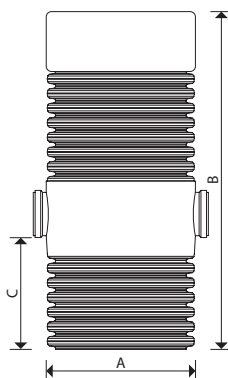

Silt Trap

- 500mm diameter x 1.25m depth
- 160mm diameter inlet and outlets

Material: Polypropylene

Nominal Size (mm)	Part Number	Dimensions (mm)		
		A	B	C
-	6LB600	500	1250	450

Ancillaries

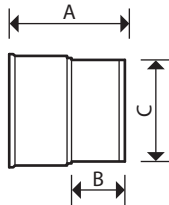

S/S Adaptor

- 6UR socket x 160mm BS EN 1401 spigot

Material: PVC-U

Nominal Size (mm)	Part Number	Dimensions (mm)		
		A	B	C
150	6UR141	180	84	160

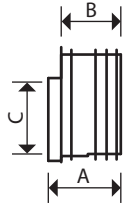

S/S Level Invert Reducer

- To 110mm OsmaDrain spigot

Material: PVC-U

Nominal Size (mm)	Part Number	Dimensions (mm)		
		A	B	C
150x110	6UR099	115	95	111

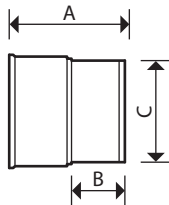

S/S Adaptor

- 6TW socket x 160mm BS EN 1401 spigot

Material: PVC-U

Nominal Size (mm)	Part Number	Dimensions (mm)		
		A	B	C
150	6TW141	180	84	160

Product Details

AquaCell Systems

Ancillaries

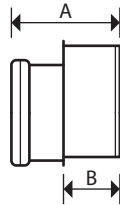

S/S Level Invert Reducer

- To 110 OsmaDrain

Material: PVC-U

Nominal Size (mm)	Part Number	Dimensions (mm)	
		A	B
160	6D099	127	70

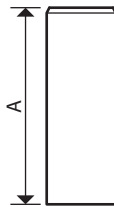

P/E Adaptor

- 160mm spigot connection

Material: PVC-U

Nominal Size (mm)	Part Number	Dimensions (mm)
		A
160	4D916	325

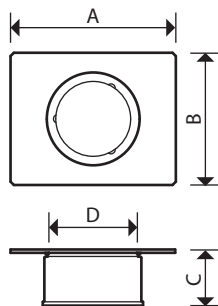
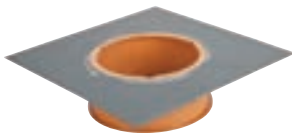

Flange Adaptor

- 6UR socket for connection of UltraRib to infiltration unit at positions other than preformed opening
- 9UR socket for connection of UltraRib to infiltration unit (can only be used with AquaCell Prime, Core and Plus)

Material: PVC-U

Nominal Size (mm)	Part Number	Dimensions (mm)			
		A	B	C	D
150	6LB104	300	300	100	160.3
225	6LB106	500	400	120	226.5

Spares

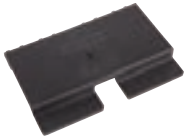

AquaCell Clip

- For jointing all AquaCell units horizontally

Material: Polypropylene

Nominal Size (mm)	Part Number
–	6LB105



AquaCell Shear Connector

- For jointing all AquaCell units vertically

Material: Polypropylene

Nominal Size (mm)	Part Number
–	6LB102

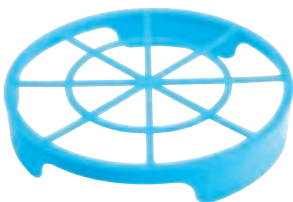

AquaCell Plus End Cap

- For blocking off unused inlets/outlets

Material: Polypropylene

Nominal Size (mm)	Part Number
–	6LB201

Discover our broad portfolio at
www.wavin.co.uk



Water management | Plumbing and heating | Waste water drainage
Water and gas distribution | Cable ducting

Wavin Limited
Registered Office
Edlington Lane
Doncaster | DN12 1BY
Tel. 0844 856 5152
www.wavin.co.uk | info@wavin.co.uk

© 2016 Wavin Limited

Wavin operates a programme of continuous product development, and therefore reserves the right to modify or amend the specification of their products without notice. All information in this publication is given in good faith, and believed to be correct at the time of going to press. However, no responsibility can be accepted for any errors, omissions or incorrect assumptions. Users should satisfy themselves that products are suitable for the purpose and application intended.

For further product information visit: wavin.co.uk



CONNECT TO BETTER